

Spare parts list

Forward and reversible plate

	Valid from serial number
LG 500 Hatz Manual start 550 mm	35010001
LG 500 Hatz Electric start 550 mm	35010001
LG 500 Hatz Manual start 550 mm Bio	35010001
LG 500 Hatz Electric start 550 mm Bio	35010001
LG 500 Hatz Electric start 700 mm	35010001
LG 500 Hatz Electric start 700 mm Bio	35010001
LG 500 Hatz Electric start 750 mm	35010001
LG 500 Hatz Manual start 750 mm	35010001
LG 500 Hatz Manual start 750 mm Bio	35010001
LG 500 Hatz Electric start 750 mm Bio	35010001
LG 500 Hatz Electric start 850 mm	35010001

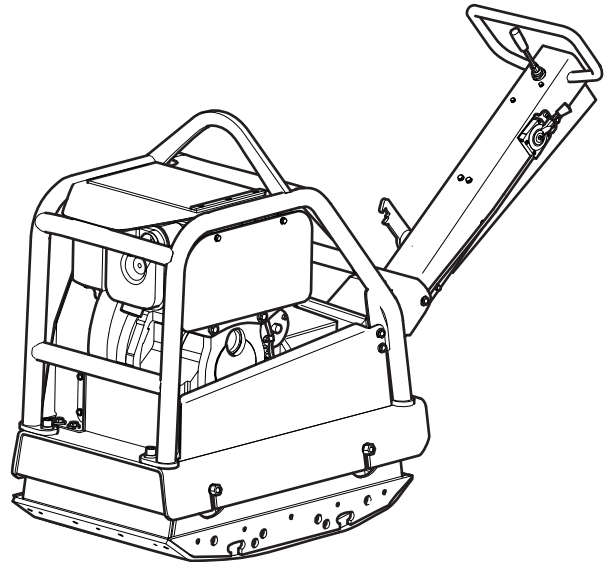



MASKINSALG A/S
 UTSTYR FOR INDUSTRI OG ANLEGG
 Blindheimsveien 1, 5131 Nyborg
www.maskinsalg.com
 SALG - SERVICE - UMLEIE Tlf. 55 19 96 20

Contents

- General information 5
- Spare parts list 6
 - Frame 6
 - Ground plate and engine plate 8
 - Ground plate and eccentric element installation 10
 - Block paving plate 750 mm (29.5 in.) 12
 - Block paving plate 850 mm (33.5 in.) 14
 - Engine installation 16
 - V-belt cover 18
 - Eccentric element 20
 - Centrifugal clutch 22
 - Belt tightner 24
 - Hydraulic system 26
 - Battery installation 28
 - Control panel 30
 - Handle 32
 - Throttle control 34
 - Labels 36
- Kits 38
 - One year service kit 38
 - Shock absorber repair kit 38
 - Eccentric element repair kit 39
 - Forward and reverse piston repair kit 39
 - Block paving plate kit 750 mm (29.5 in.) 40
 - Block paving plate kit 850 mm (33.5 in.) 41
 - Extension plate kit 2 x 75 mm (2 x 2.95 in.) 42
 - Extension plate kit 2 x 150 mm (2 x 5.90 in.) 43
 - Slanted extension plate kit 2 x 150 mm (2 x 5.90 in.) 44
 - Hour meter kit 45
 - Safety crank handle kit 46

General information

This spare parts list applies to the following:

Part number	Description
3382 0000 54	Forward and reversing plate LG 500 Hatz Manual start 550 mm (21.65 in.)
3382 0000 55	Forward and reversing plate LG 500 Hatz Electric start 550 mm (21.65 in.)
3382 0000 58	Forward and reversing plate LG 500 Hatz Manual start 550 mm (21.65 in.) Bio
3382 0000 59	Forward and reversing plate LG 500 Hatz Electric start 550 mm (21.65 in.) Bio
3382 0000 63	Forward and reversing plate LG 500 Hatz Electric start 700 mm (27.56 in.) (550 mm plus 2 x 75 mm / 21.65 in. plus 2 x 2.95 in.)
3382 0000 64	Forward and reversing plate LG 500 Hatz Electric start 700 mm (27.56 in.) Bio (550 mm plus 2 x 75 mm / 21.65 in. plus 2 x 2.95 in.)
3382 0000 56	Forward and reversing plate LG 500 Hatz Electric start 750 mm (29.50 in.)
3382 0000 57	Forward and reversing plate LG 500 Hatz Manual start 750 mm (29.50 in.)
3382 0000 60	Forward and reversing plate LG 500 Hatz Manual start 750 mm (29.50 in.) Bio
3382 0000 61	Forward and reversing plate LG 500 Hatz Electric start 750 mm (29.50 in.) Bio
3382 0000 62	Forward and reversing plate LG 500 Hatz Electric start 850 mm (35.50 in.) (550 mm plus 2 x 150 mm / 21.65 in. plus 2 x 5.91 in.)

Use only authorized parts. Any damage or malfunction caused by the use of unauthorized parts is not covered by Warranty or Product Liability. Any unauthorized use or copying of the contents or any part thereof is prohibited. This applies in particular to trademarks, model denominations, part numbers, and drawings.

Instructions for use

This spare parts list contains no safety regulations and is merely intended to assist in the ordering of spare parts.

For information about operating, servicing, or repairing, the relevant Safety and operating instructions must be consulted at all costs.

Please observe the safety instructions listed in the relevant Safety and operating instructions!

Spare parts list

Frame

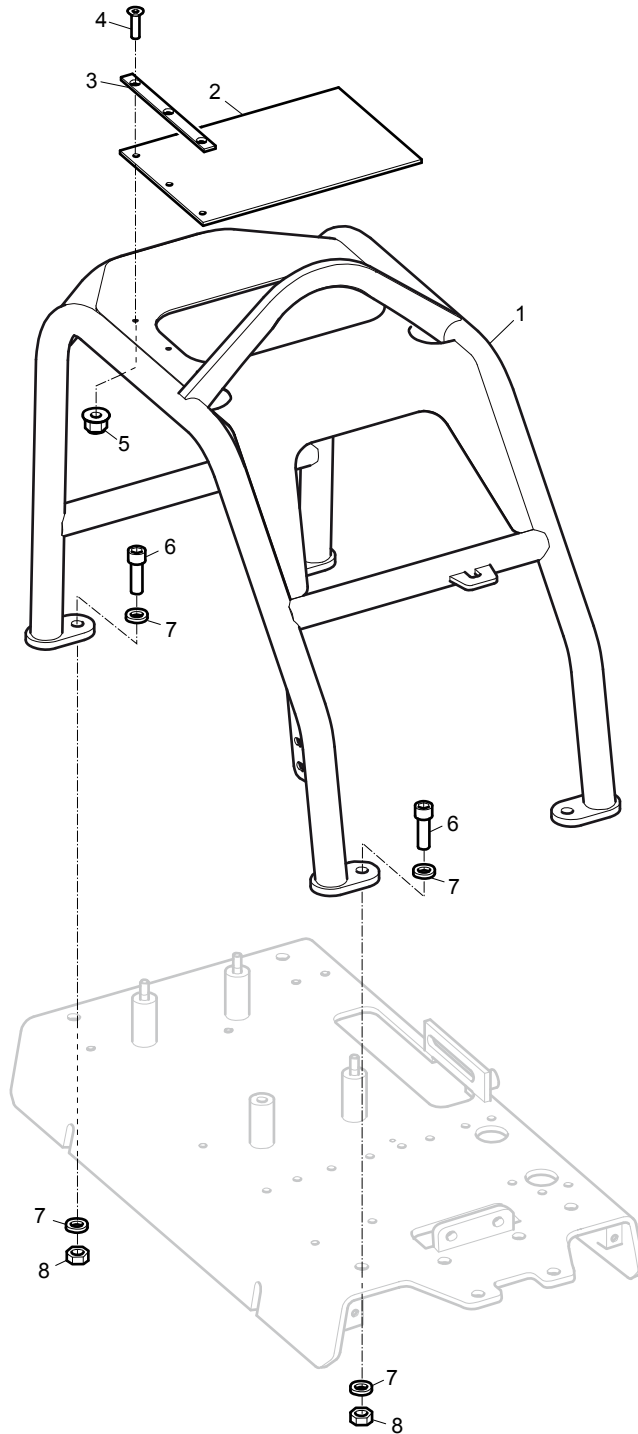

No.	Description	Remark	Quantity	Part number
1	Protective frame		1	3382 0104 76
2	Cover		1	4700 2814 85
3	Bracket		1	4700 2814 84
4	Screw	M8 x 30 mm 8.8 A3K	3	-
5	Lock nut	M8 x 1.25 mm A2K	3	-
6	Screw	M16 x 60 mm 8.8 A3K	4	-
7	Washer	17 x 30 x 6 mm 0.70 x 1.18 x 0.24 in. 300 HV	8	-
8	Lock nut	M16 ISO7040	4	-

Ground plate and engine plate

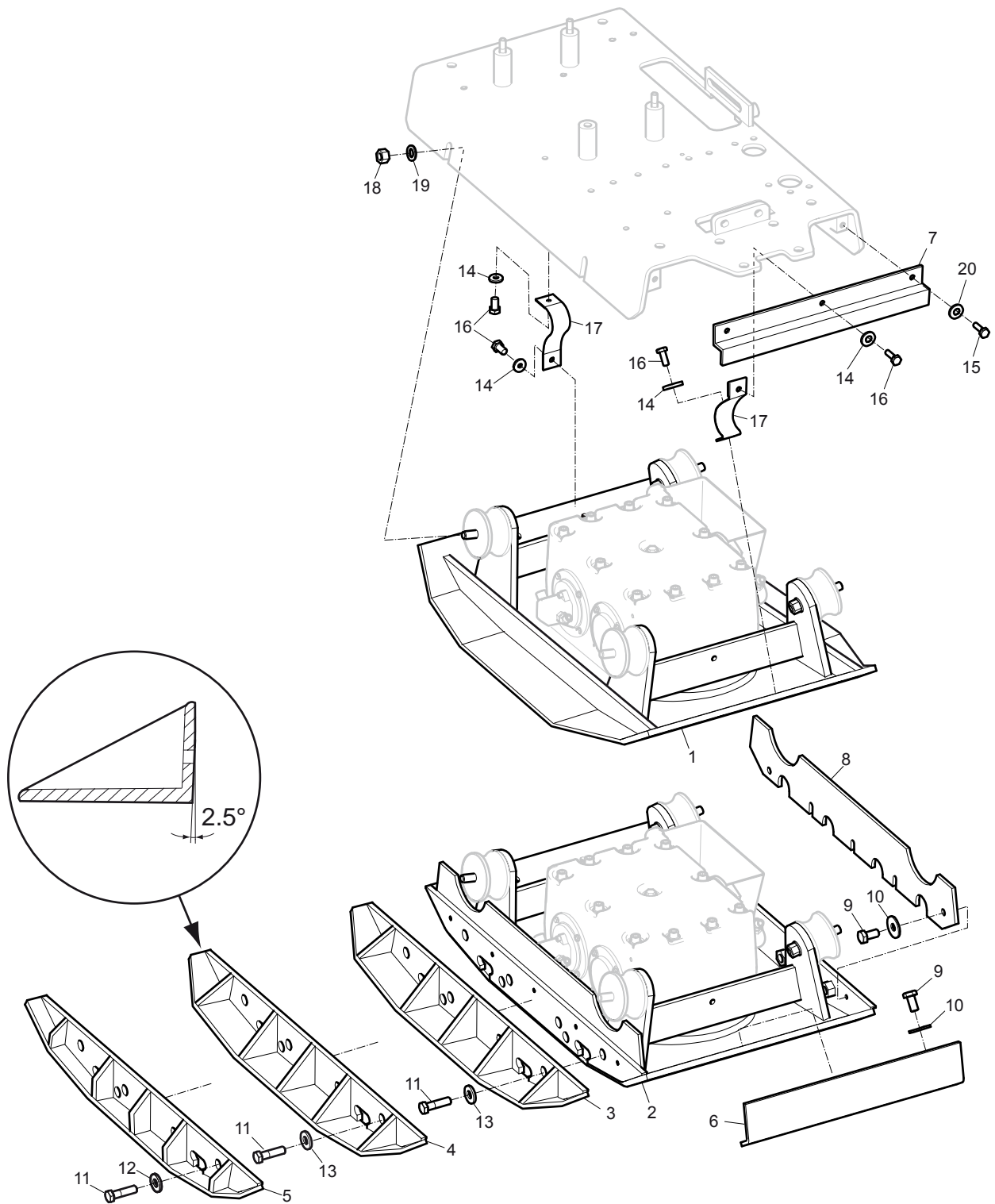

No.	Description	Remark	Quantity	Part number
1	Ground plate	750 mm 29.53 in.	1	4700 3891 08
2	Ground plate	550 mm 21.65 in.	1	4700 2827 14
3	Extension plate	150 mm 5.91 in.	2	4700 2805 44
4	Extension plate	Slanted 2.5°, 150 mm 5.91 in.	2	4700 2827 39
5	Extension plate	75 mm 2.95 in.	2	4812 0706 77
6	Plastic cover		1	4700 3863 49
7	Plate		1	3382 0104 79
8	Plastic cover		2	4700 2827 04
9	Screw	M10 x 20 mm 8.8 A3K	13	-
10	Washer		13	4700 9284 41
11	Screw		8	4700 5001 01
12	Washer		8	4700 9032 90
13	Washer		1	4700 6150 47
14	Washer	13 x 36 x 6 mm 0.51 x 1.42 x 0.24 in. 300 HV	5	-
15	Screw	M12 x 25 mm 8.8 A3K	2	-
16	Screw	M12 x 20 mm 8.8 A3K	4	-
17	Strap		2	3382 0100 21
18	Nut	M16 A3K	4	4700 5700 08
19	Washer	17 x 30 x 3 mm 0.70 x 1.18 x 0.12 in. 300 HV	4	-
20	Washer	13 x 30 x 4 mm 0.51 x 1.18 x 0.16 in. 300 HV	2	-

Ground plate and eccentric element installation

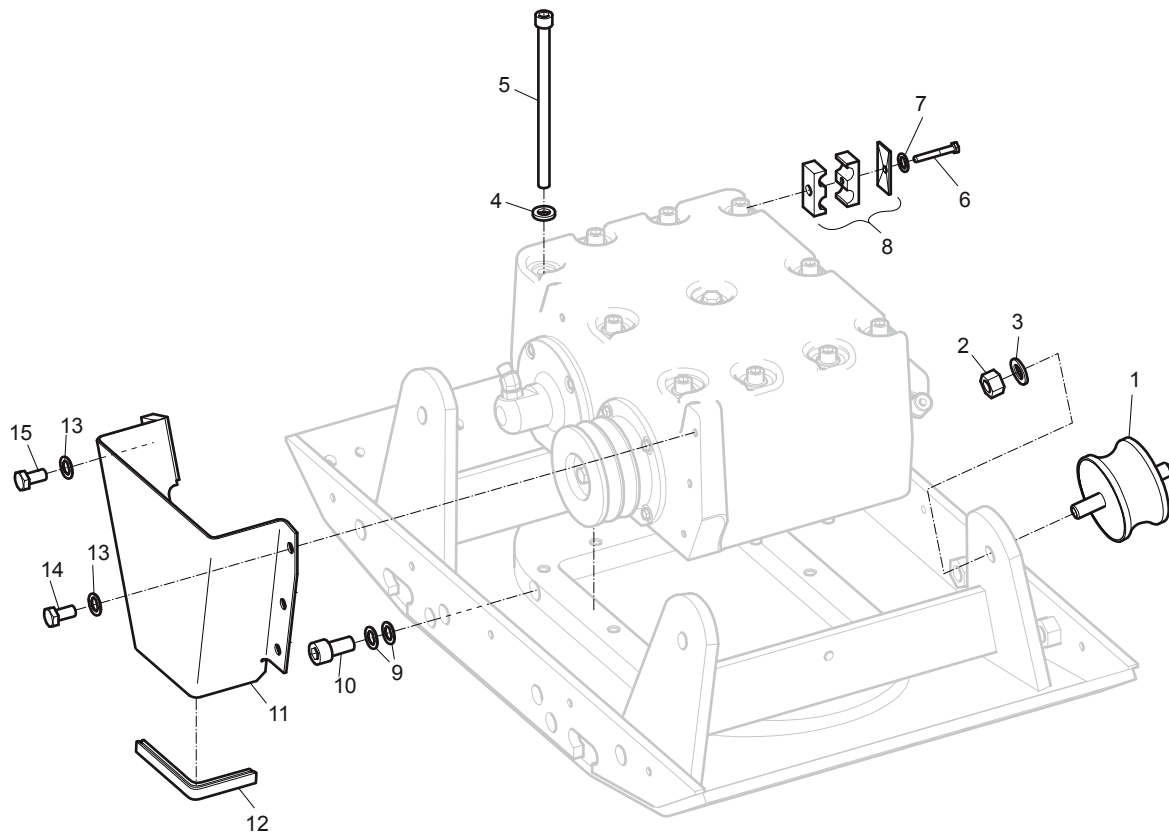

No.	Description	Remark	Quantity	Part number
1	Shock absorber		4	4700 2804 54
2	Nut	M16 A3K	4	-
3	Washer	17 x 30 x 3 mm 0.70 x 1.18 x 0.12 in. 300 HV	4	-
4	Washer	13 x 30 x 4 mm 0.51 x 1.18 x 0.16 in. 300 HV	10	-
5	Screw	M12 x 200 mm 12.9 GEOMET®	10	4700 9289 44
6	Screw	M8 x 60 mm 8.8 A2K	1	-
7	Washer	8.4 x 16 x 1.5 mm 0.33 x 0.63 x 0.06 in. 300 HV	1	-
8	Hose holder		1	4700 3834 58
9	Washer	10 x 16 x 1 mm 0.39 x 0.63 x 0.04 in.	2	-
10	Screw	M10 x 20 mm	1	-
11	Belt guard		1	4700 2804 34
12	Edge trim	165 mm 6.50 in.	1	-
13	Washer	8.4 x 16 x 1.5 mm 0.33 x 0.63 x 0.06 in. 300 HV	5	-
14	Screw	M8 x 16 mm 8.8 A3K	3	-
15	Screw	M8 x 30 mm	2	-

GEOMET is a registered trademark of Nof Metal Coatings North America Inc.

Block paving plate 750 mm (29.5 in.)

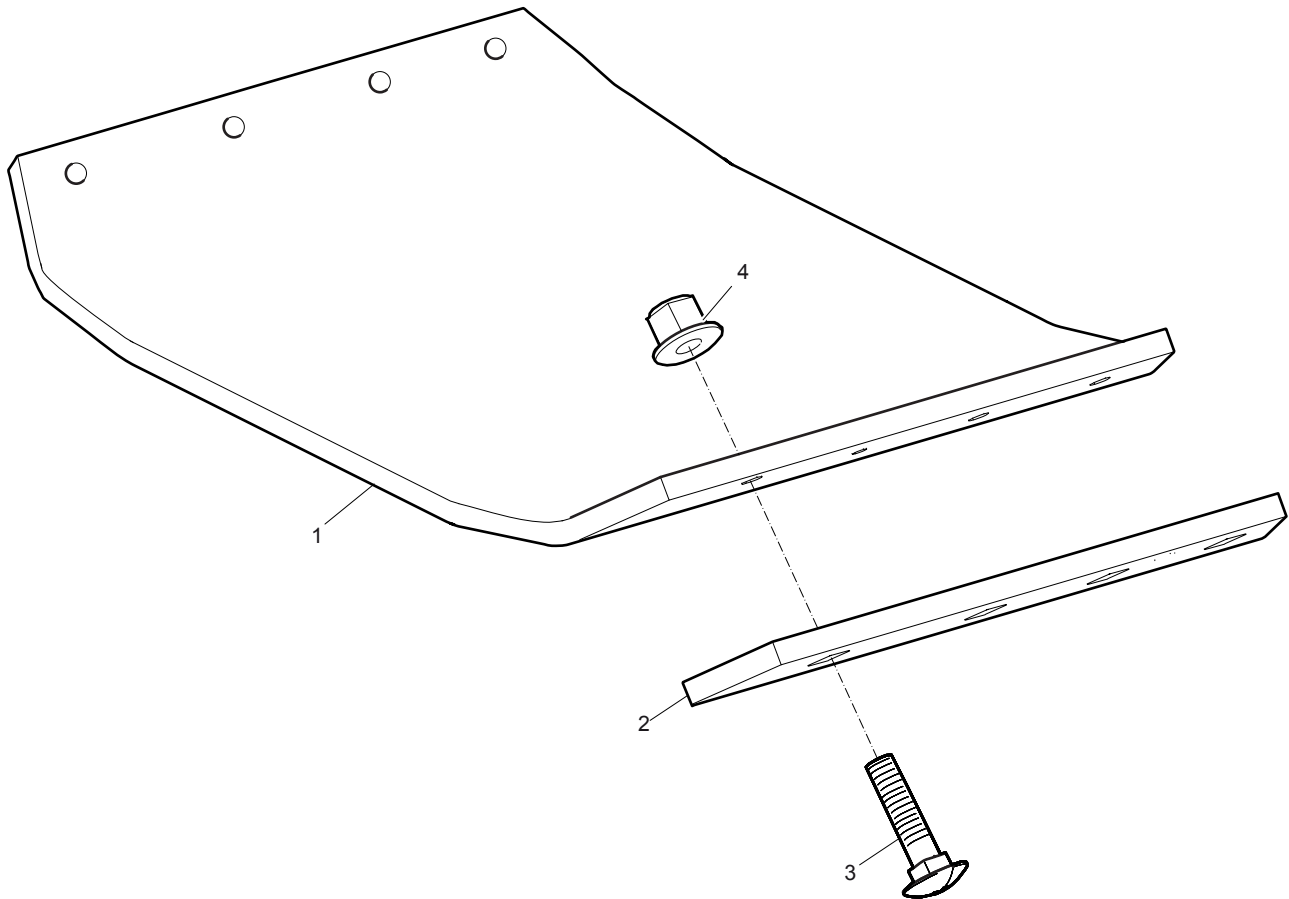

No.	Description	Remark	Quantity	Part number
1	Ground plate	Polyurethane	1	4700 2808 88
2	Bracket		2	4700 3820 08
3	Screw	M10 x 50 mm 4.6 A3K	8	-
4	Lock nut	M10 x 1.5 mm A3K	8	-

Block paving plate 850 mm (33.5 in.)

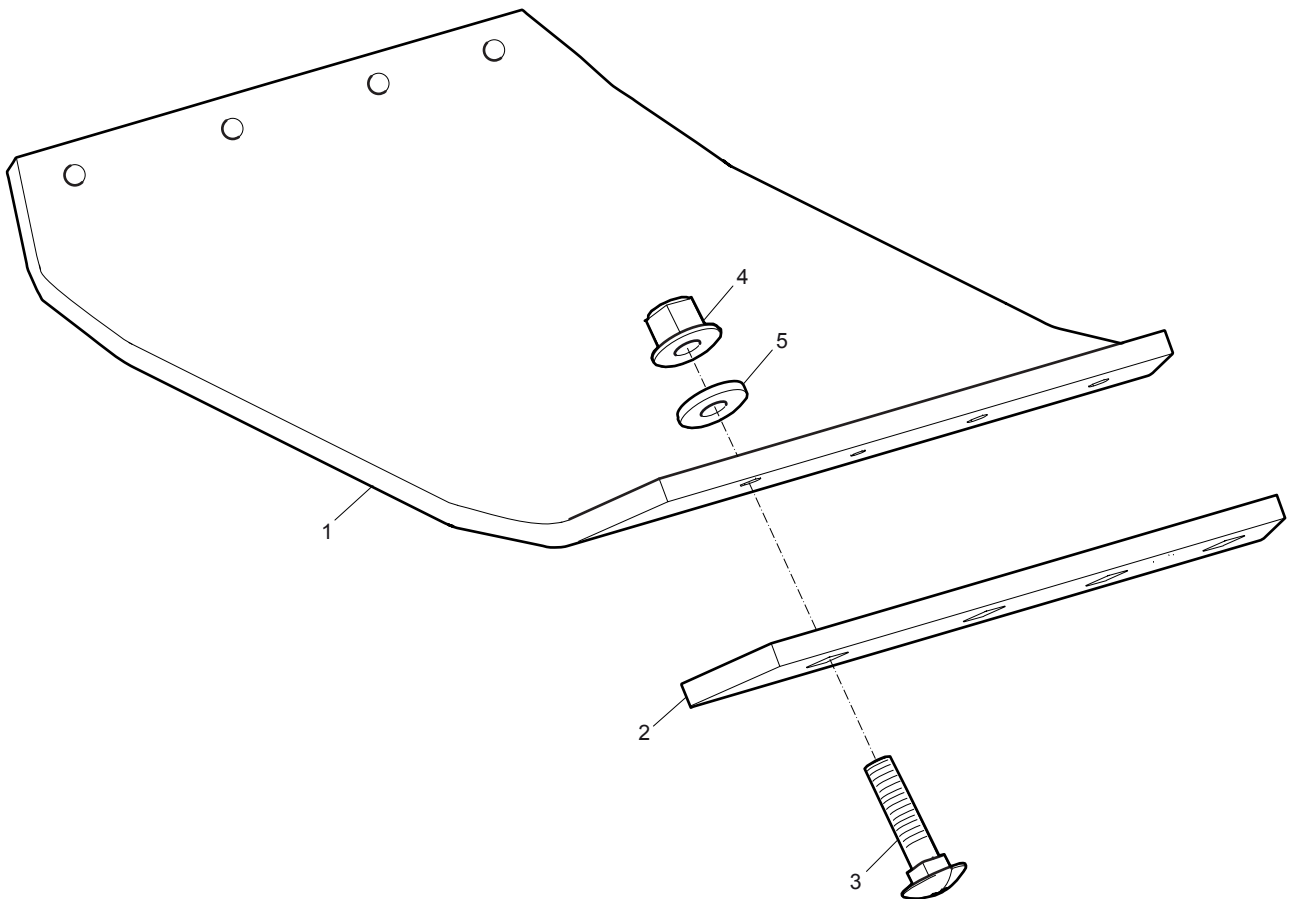

No.	Description	Remark	Quantity	Part number
1	Ground plate	Polyurethane	1	4700 3819 03
2	Bracket		2	4700 3819 02
3	Screw	M10 x 50 mm 8.8 A3K	8	-
4	Lock nut	M10	8	-
5	Washer	10.5 x 22 x 2 mm 0.41 x 0.87 x 0.08 in. 300 HV	8	-

No.	Description	Remark	Quantity	Part number
1	Engine plate		1	3382 0104 75
2	Engine, complete	Hatz 1D81Z, electric start	1	4700 3952 43
3	Engine, complete	Hatz 1D81Z, manual start	1	4700 3952 42
4	Nut	M12	4	-
5	Washer	13 x 24 x 6 mm 0.51 x 0.95 x 0.16 in. 300 HV	4	-
6	Stud		4	4700 3947 00
7	Bracket		1	4700 3863 69
8	Insulation washer		5	4700 3734 76
9	Insulation		1	4700 3863 93
10	Cover		1	4700 3863 13
11	Washer	13 x 30 x 4 mm 0.51 x 1.18 x 0.16 in. 300 HV	2	-
12	Screw	M12 x 45 mm 8.8 A3K	2	-
13	Washer	8.4 x 16 x 3 mm 0.33 x 0.63 x 0.12 in. 300 HV	2	-
14	Screw	M8 x 25 mm 8.8 A2K	2	-
15	Engine shaft		1	4700 2811 94
16	Key		1	4700 3500 36
17	Washer	8.4 x 16 x 3 mm 0.33 x 0.63 x 0.12 in. 300 HV	4	-
18	Screw	M8 x 30 mm	4	-
19	V-belt		2	4700 3863 12
20	Washer	13 x 30 x 4 mm 0.51 x 1.18 x 0.16 in. 300 HV	2	-
21	Screw	M10 x 20 mm 8.8 A3K	1	-
22	Screw	M12 x 25 mm 8.8 A3K	1	-
23	Washer	13 x 36 x 6 mm 0.51 x 1.42 x 0.24 in. 300 HV	1	-
24	Spacer		1	4700 3942 30
25	Bracket		1	3382 0101 82
26	Rubber block		1	4700 2805 34
27	Screw	M8 x 60 mm 8.8 A2K	2	-
28	Safety crank		1	4700 2393 82
29	Screw	M8 x 20 mm 8.8 A2K	2	-
30	Washer	8.4 x 16 x 1.5 mm 0.33 x 0.63 x 0.06 in. 300 HV	4	-
31	Crank holder		1	4700 2811 83
32	Nut	M8	2	-

V-belt cover

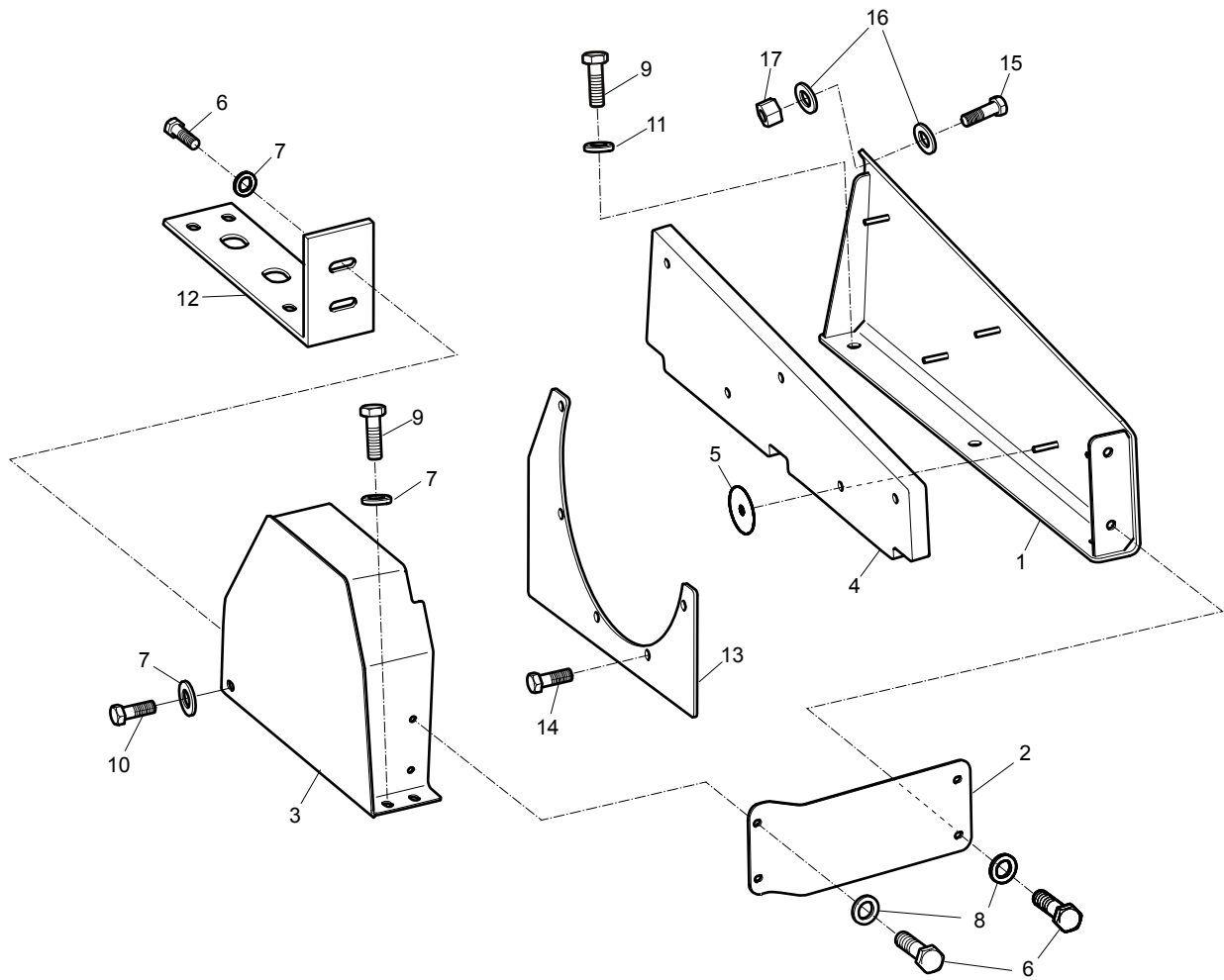

No.	Description	Remark	Quantity	Part number
1	Protective cover		1	3382 0104 80
2	Bracket		1	3382 0104 81
3	V-belt cover		1	3382 0104 78
4	Insulation		1	4700 3865 99
5	Insulating washer		5	4700 3734 76
6	Screw	M12 x 25 mm 8.8 A3K	6	-
7	Washer	13 x 30 x 4 mm 0.51 x 1.18 x 0.16 in. 300 HV	5	-
8	Washer	8.4 x 16 x 3 mm 0.33 x 0.63 x 0.12 in. 300 HV	4	-
9	Screw	M12 x 25 mm 8.8 A3K	5	-
10	Screw	M12 x 20 mm 8.8 A3K	1	-
11	Washer	13 x 30 x 4 mm 0.51 x 1.18 x 0.16 in. 300 HV	3	-
12	Bracket		1	4700 3946 99
13	Plate		1	4700 3863 16
14	Screw	M10 x 20 mm 8.8 A3K	5	-
15	Screw	M10 x 30 mm 8.8 A3K	2	-
16	Washer	10.5 x 22 x 4 mm 0.41 x 0.87 x 0.16 in. 300 HV	4	-
17	Nut	M10 A3K	2	-

Eccentric element

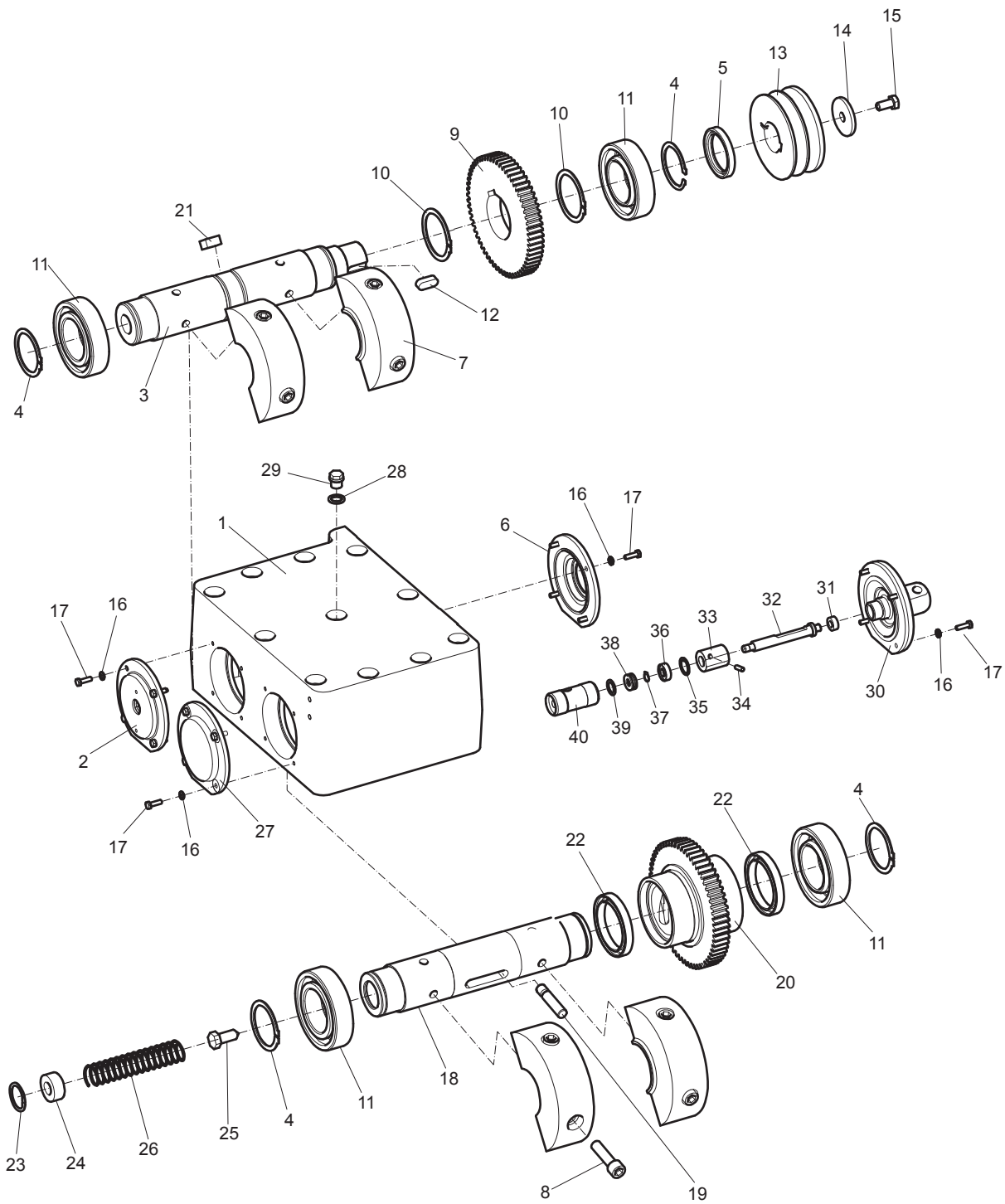

No.	Description	Remark	Quantity	Part number
1	Eccentric housing		1	4700 3975 20
2	Cover		1	4700 3790 79
3	Shaft		1	4700 3779 86
4	Retainer ring		4	4700 1500 33
5	Sealing ring		1	4700 9287 94
6	Cover		1	4700 3790 80
7	Eccentric weight		4	4700 3975 22
8	Screw	M12 x 45 mm 8.8 A3K	8	4700 9287 91
9	Gear		1	4700 3782 16
10	Snap ring		2	4700 1500 20
11	Ball bearing		4	4700 9287 86
12	Key		1	4700 9287 88
13	Pulley		1	4700 3777 76
14	Washer		1	4700 2804 32
15	Screw	M10 x 20 mm 8.8 A3K	1	-
16	Washer	6.4 x 12 x 1.5 mm 0.25 x 0.47 x 0.06 in. 300 HV	16	-
17	Screw	M6 x 20 mm 8.8 A2K	16	-
18	Eccentric weight		1	4812 0700 73
19	Pin		1	4700 2804 42
20	Reverser		1	4812 0700 93
21	Key		1	4700 2804 50
22	Ball bearing		2	4700 9287 96
23	Retainer ring		1	4700 9287 87
24	Stop		1	4700 2804 48
25	Stop screw		1	4700 2804 49
26	Spring		1	4700 9287 98
27	Cover		1	4700 3790 81
28	Washer	16.7 x 24 x 1.5 mm Type A M16 0.66 x 4.88 x 0.06 in.	1	4700 1620 11
29	Plug		1	4700 2321 43
30	Hydraulic cylinder		1	4812 0700 42
31	Sealing ring		1	4700 2812 76
32	Piston rod		1	4812 0700 44
33	Cap		1	4812 0700 43
34	Spring pin		1	4700 6290 62
35	Retainer ring		1	4700 1510 39
36	Ball bearing		1	4812 0703 59
37	Retainer ring		1	4700 1500 02
38	Thrust ball bearing		1	4812 0703 62
39	Spring washer		1	4812 0703 63
40	Piston		1	4812 0700 52

Centrifugal clutch

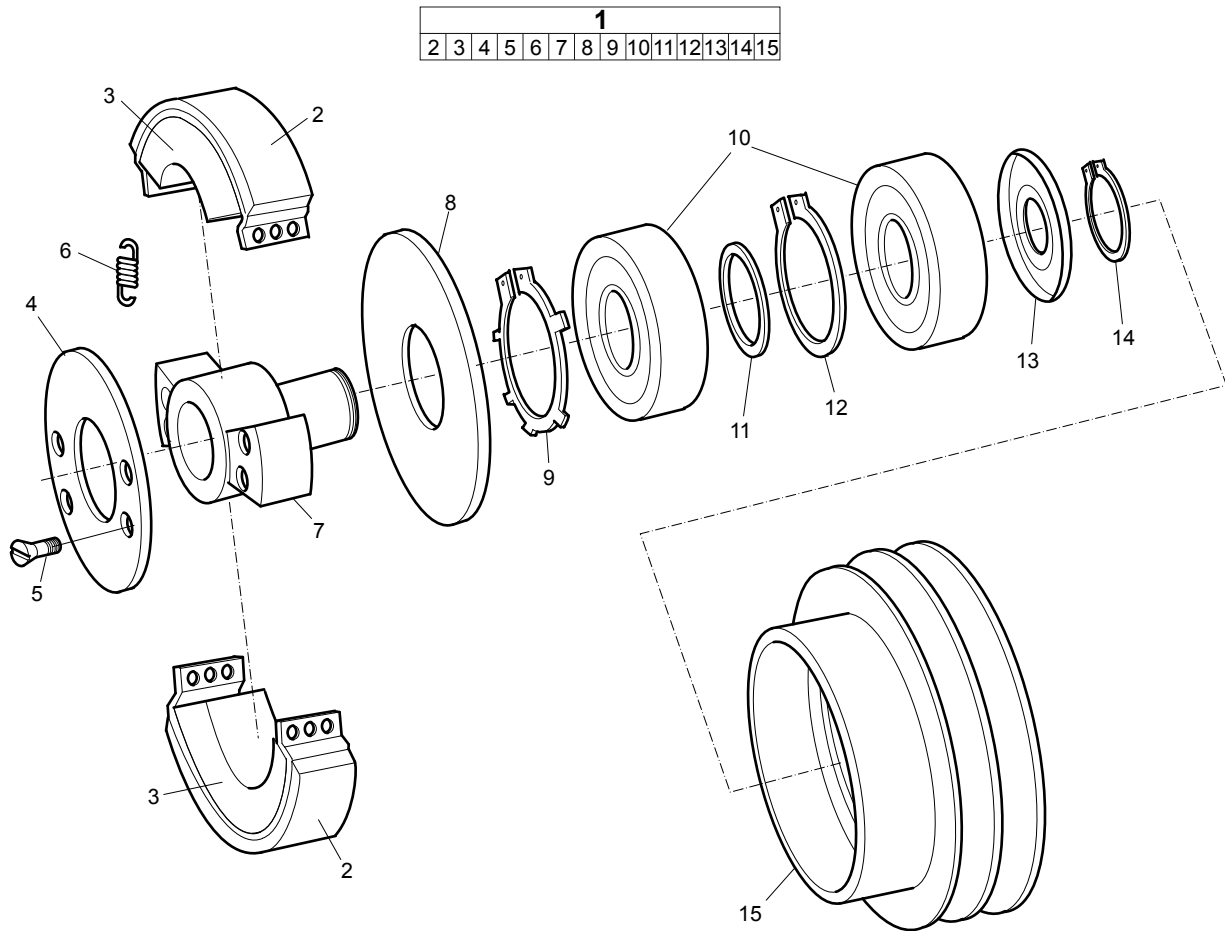

No.	Description	Remark	Quantity	Part number
1(2-15)	Centrifugal clutch, complete		1	4812 0702 88
2	Cluch		2	4700 9393 59
3	Weight		2	4700 9393 58
4	Cover		1	4700 9393 60
5	Screw		4	4700 9393 61
6	Spring		4	4700 4212 46
7	Hub		1	4700 9393 57
8	Cover		1	4700 9393 62
9	Lock washer		1	4700 9393 63
10	Ball bearing		2	3382 1000 08
11	Washer		1	4700 9393 56
12	Retainer ring		1	4700 9387 25
13	Nilos ring		1	4700 9387 27
14	Snap ring		1	4700 9387 26
15	V-belt pulley		1	4700 9393 55

Belt tightner

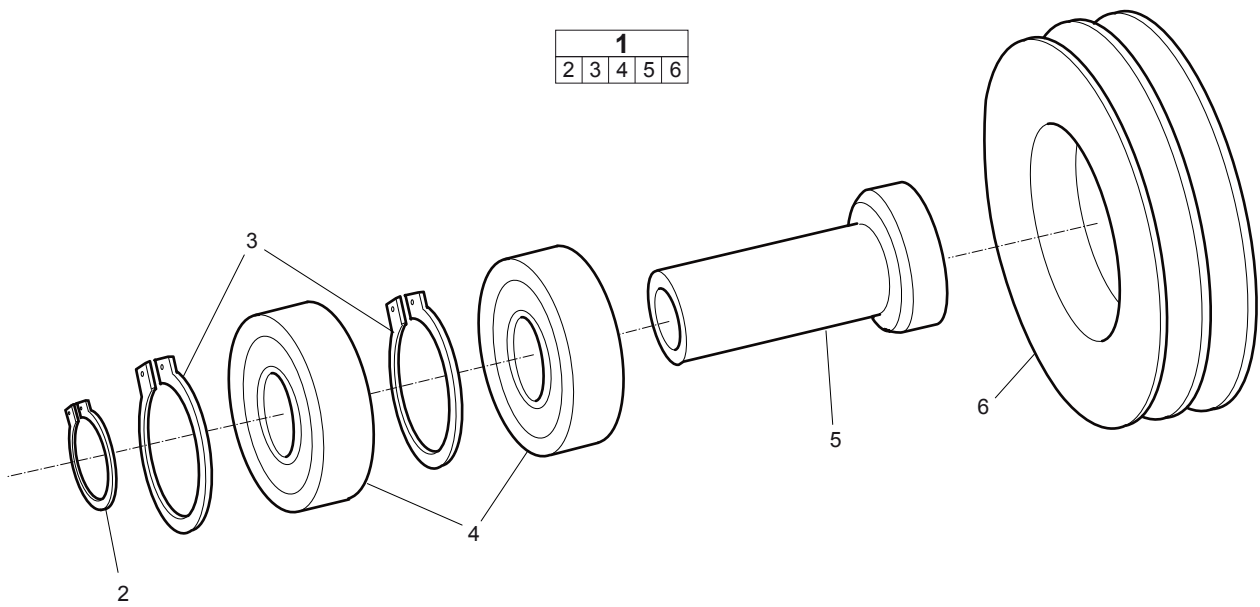

No.	Description	Remark	Quantity	Part number
1(2-6)	Belt tightner, complete		1	4700 3780 60
2	Snap ring		1	4700 1500 12
3	Retainer ring		2	4700 1510 19
4	Ball bearing		2	4700 1111 80
5	Shaft		1	4700 3780 61
6	V-belt pulley		1	4700 3805 17

Hydraulic system

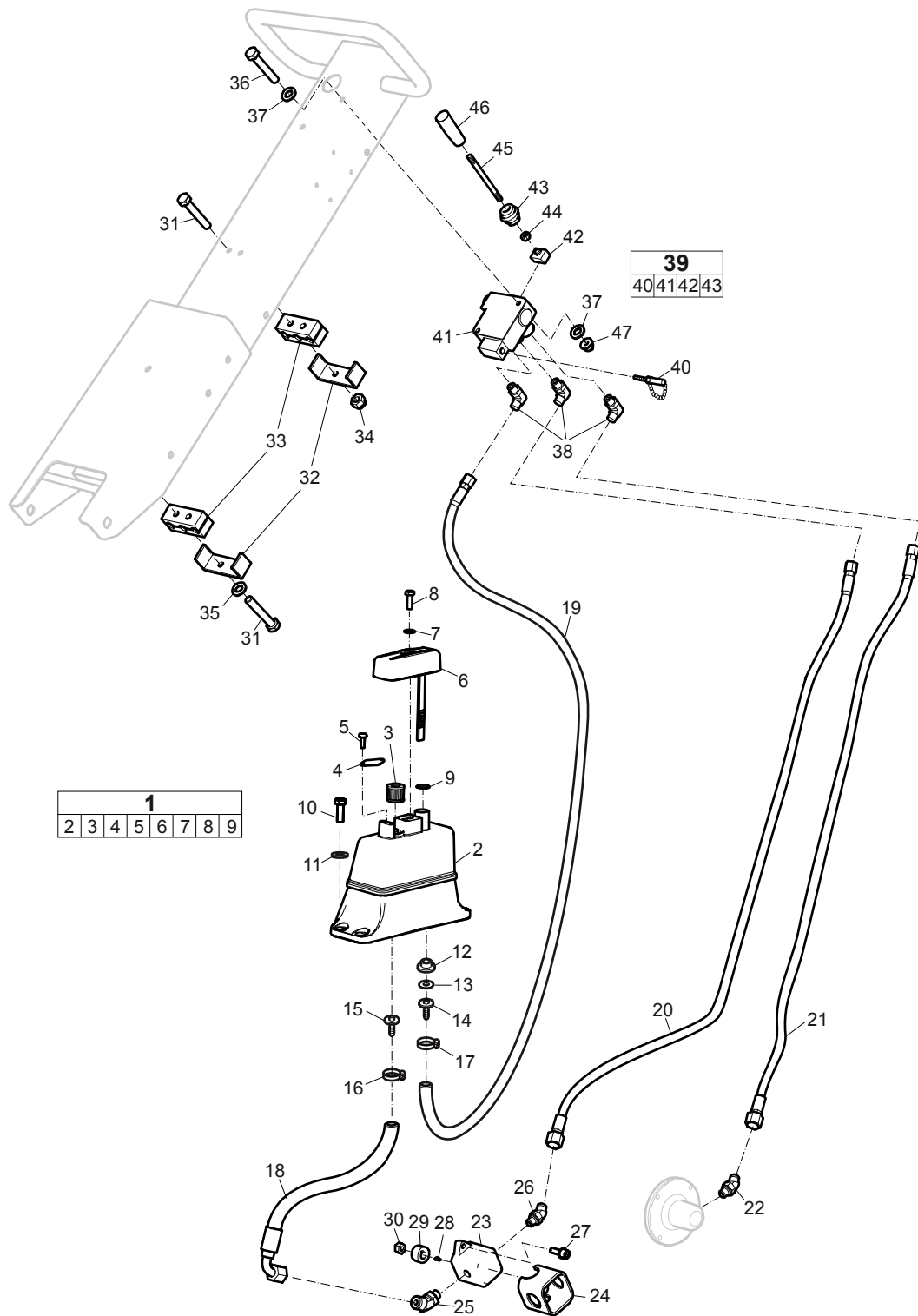

No.	Description	Remark	Quantity	Part number
1(2-9)	Hydraulic oil tank, complete		1	4700 3766 76
2	Tank		1	-
3	Air filter		1	4700 3815 66
4	Holder		1	4700 3815 63
5	Screw	K50 x 12 mm Type KX-PT	2	-
6	Cover		1	4700 3813 85
7	Washer	8.4 x 16 x 1.5 mm 0.33 x 0.63 x 0.06 in. 300 HV	1	-
8	Screw	M8 x 25 mm 8.8 A2K	1	-
9	O-ring	15.3 x 2.4 mm 0.64 x 0.09 in. (Shore 70)	1	-
10	Screw	M10 x 55 mm 8.8 A3K	4	-
11	Washer	10.5 x 22 x 2 mm 0.41 x 0.87 x 0.08 in. 300 HV	4	-
12	Reducer		1	4700 3830 39
13	Washer	13.3 x 18.9 x 1.5 mm 0.52 x 0.74 x 0.06 in. Copper	1	-
14	Hose coupling		1	4700 3833 53
15	Hose coupling		1	4700 3830 38
16	Hose clamp		1	4700 3130 03
17	Hose clamp		1	4700 3131 08
18	Hydraulic hose		1	4812 0704 26
19	Hydraulic hose	Connected to port "T"	1	4812 0704 27
20	Hydraulic hose	Connected to port "B"	1	4811 0001 87
21	Hydraulic hose	Connected to port "P"	1	4700 4842 08
22	Elbow connector	45°	1	4700 2344 81
23	Hydraulic pump		1	4700 3835 62
24	Cover		1	4700 2805 40
25	Elbow connector	45°	1	4700 7922 53
26	Elbow connector	45°	1	4700 7924 43
27	Screw	M6 x 20 mm 8.8 A2K	2	-
28	Key		1	-
29	Sleeve		1	4700 9288 94
30	Nut		1	-
31	Screw	M8 x 50 mm 8.8 A2K	4	-
32	Bracket		2	3382 0101 82
33	Rubber block		2	4700 2805 34
34	Lock nut	M8 x 1.25 mm A2K	2	-
35	Washer	8.4 x 18 x 2 mm 0.33 x 0.71 x 0.08 in.	2	-
36	Screw	M6 x 50 mm 8.8 A2K	2	-
37	Washer	6.4 x 14 x 2 mm 0.25 x 0.55 DIN 6796.	4	-
38	Elbow connector	90°	3	-
39(40-43)	Valve, complete		1	4700 2813 75
40	Measuring nipple		1	4700 9381 63
41	Valve		1	-
42	Lever housing		1	4700 9379 24
43	Rubber cover		1	4700 9365 95
44	Nut	M8 A2K	1	-
45	Rod		1	3382 0104 89
46	Grab handle		1	4700 9038 21
47	Nut	M6 x 1 mm A2K	2	-

Battery installation

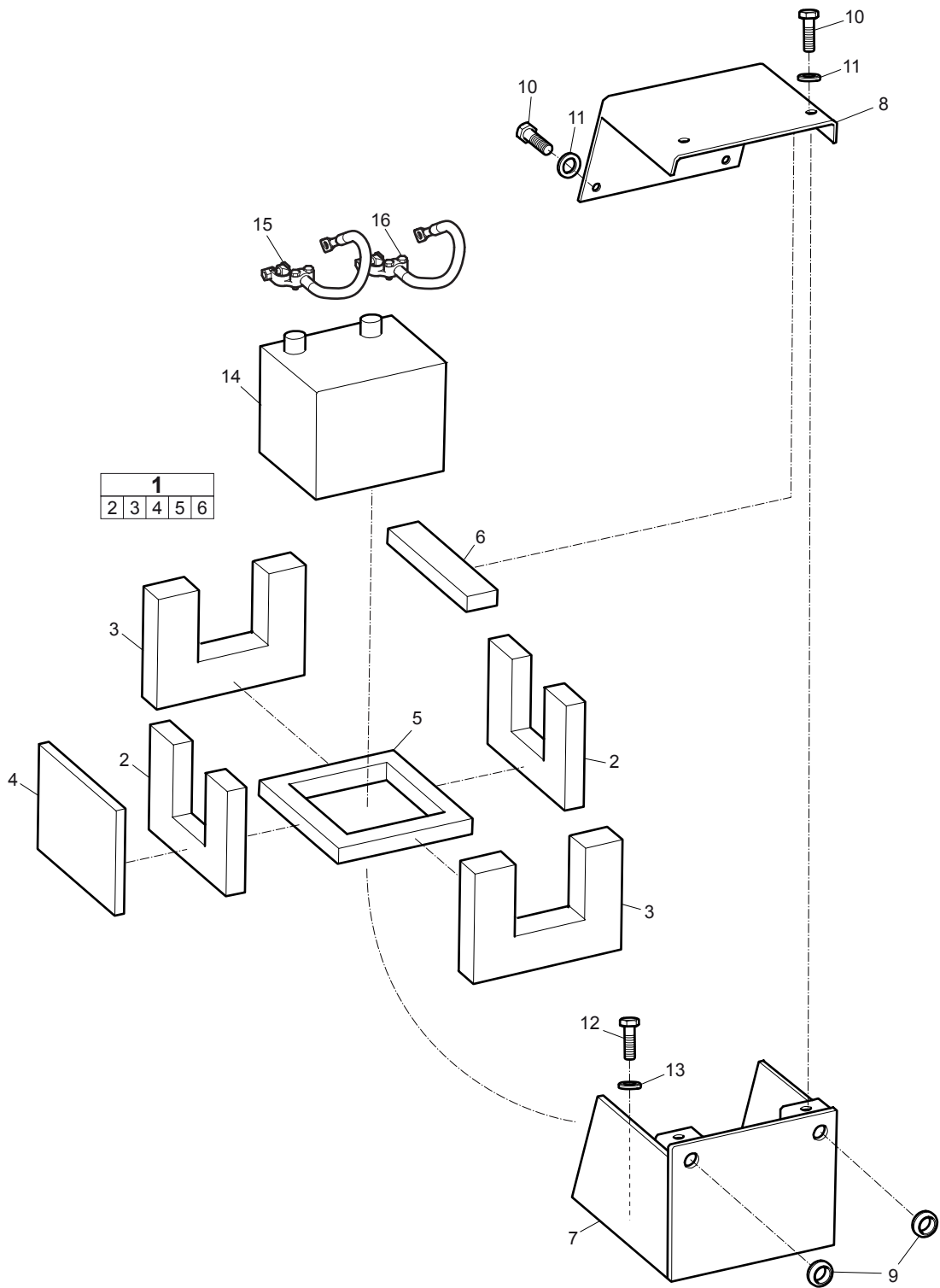

No.	Description	Remark	Quantity	Part number
1(2-6)	Insulation kit		1	4700 2818 95
2	Insulation		2	-
3	Insulation		2	-
4	Insulation		1	-
5	Insulation		1	-
6	Insulation		1	-
7	Battery box		1	3382 0104 88
8	Cover		1	3382 0104 87
9	Grommet		2	4700 9292 00
10	Screw	M8 x 16 mm 8.8 A2K	4	-
11	Washer	8.4 x16 x1.5 mm 0.33 x 0.63 x 0.06 in. 300 HV	4	-
12	Screw	M10 x 16 mm 8.8 A3K	1	-
13	Washer	10.5 x 22 x 4 mm 0.41 x 0.87 x 0.16 in. 300 HV	1	-
14	Battery		1	4700 2818 96
15	Battery cable	Connected to negative terminal of battery	1	4700 2812 02
16	Battery cable	Connected to positive terminal of battery	1	4700 2812 01

Control panel

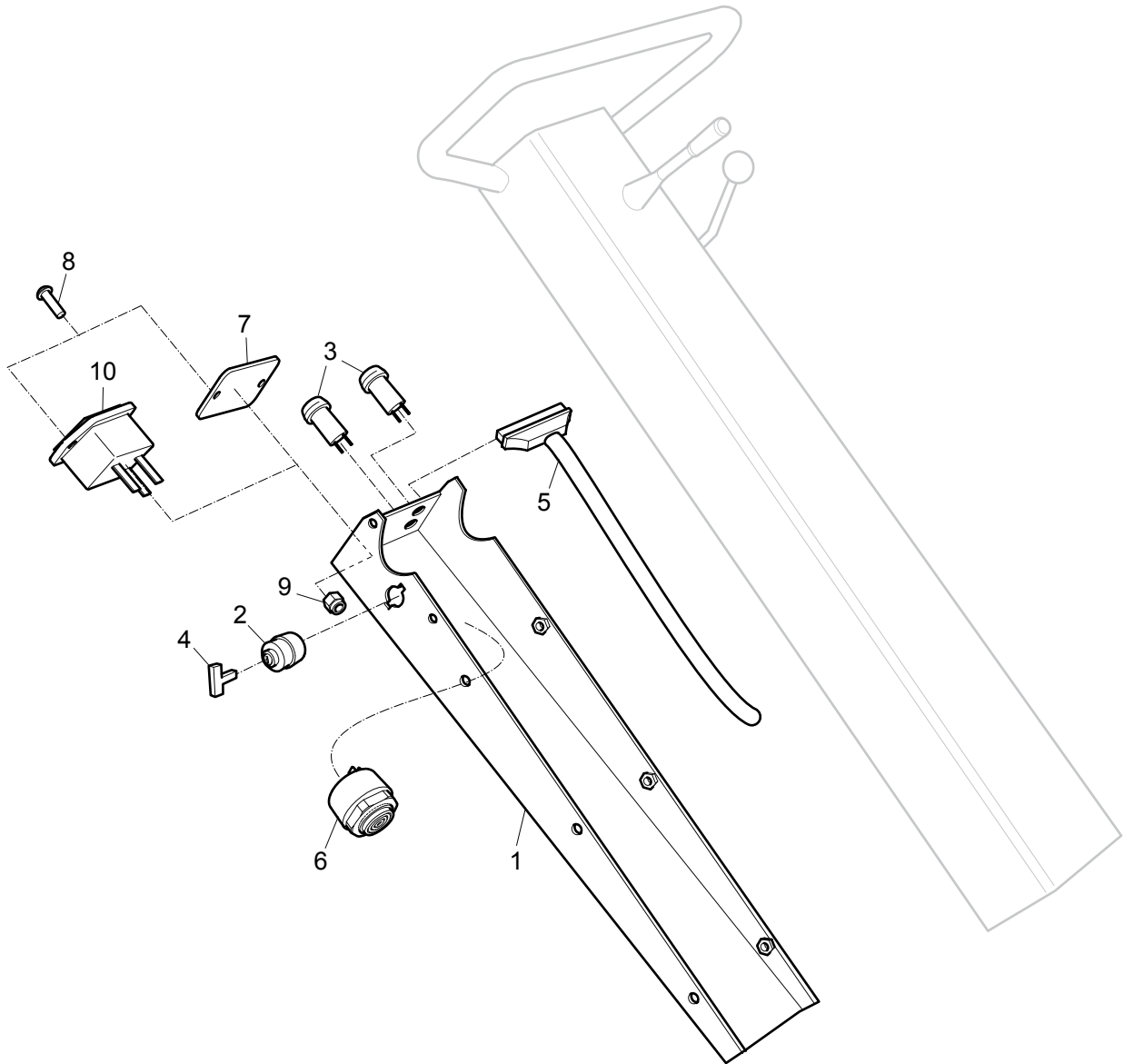

No.	Description	Remark	Quantity	Part number
1	Cover		1	4700 3782 23
2	Ignition switch		1	4700 2381 58
3	Diode lamp		2	4700 7910 58
4	Ignition key		1	4700 2382 36
5	Cable harness		1	4700 3782 25
6	Buzzer		1	4700 3855 99
7	Cover		1	4700 3768 67
8	Screw	M3 x 10 mm 8.8 A2-70	1	-
9	Lock nut	M3 DIN985	1	-
10	Hour meter		1	4700 3856 00

Handle

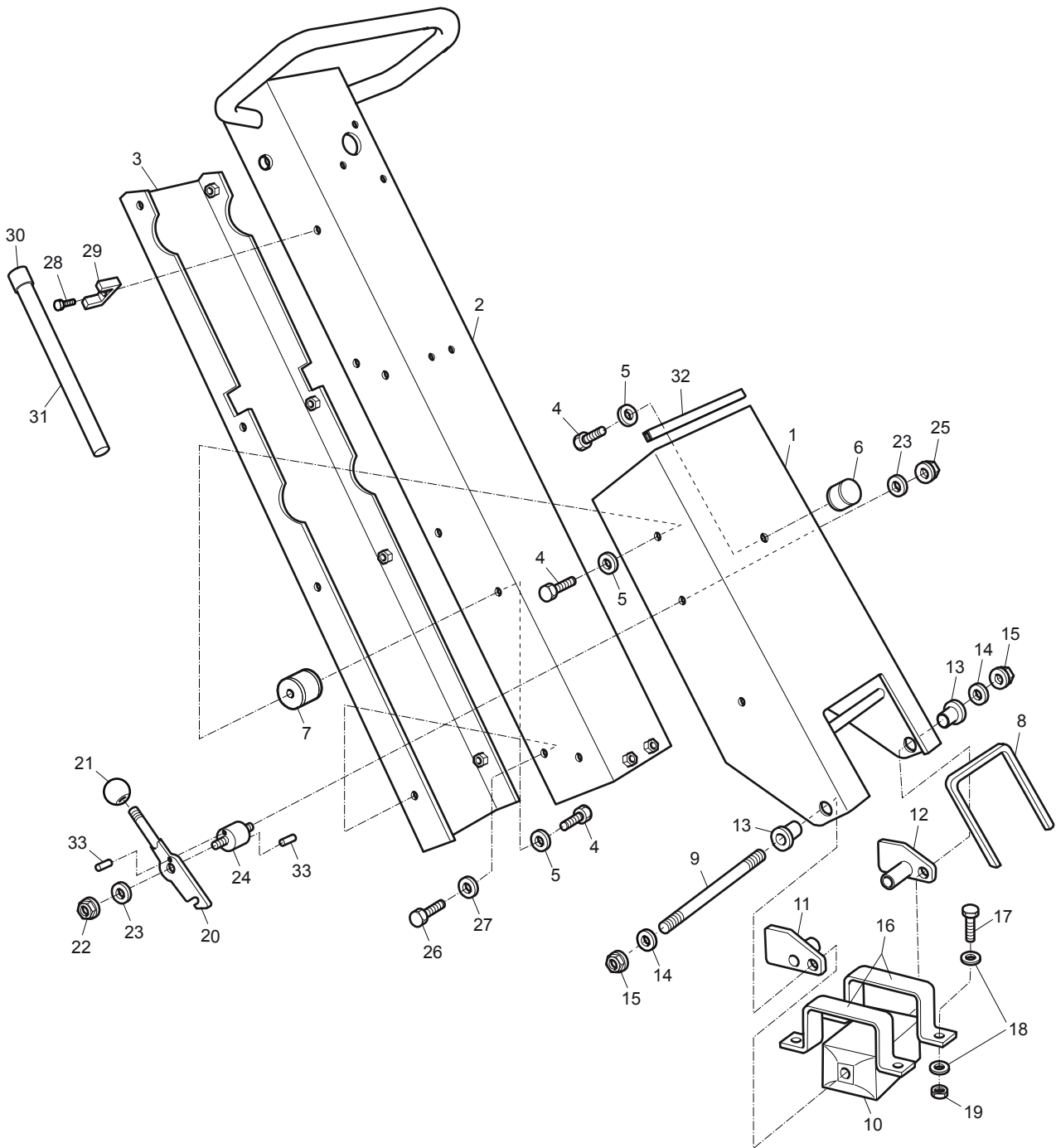

No.	Description	Remark	Quantity	Part number
1	Handle	Bracket	1	3382 0104 85
2	Handle		1	3382 0104 86
3	Cover	Hatz manual start	1	4700 3773 12
4	Screw	M10 x 16 mm 8.8 A3K	9	-
5	Washer	10.5 x 22 x 2 mm 0.41 x 0.87 x 0.08 in. 300 HV	9	-
6	Rubber stop		1	4700 2818 04
7	Shock absorber		4	3382 0104 90
8	Edge trim	165 mm 6.50 in.	1	4700 9023 79
9	Stud		1	3382 0104 91
10	Shock absorber		1	3382 0104 92
11	Retainer	Right	1	3382 0104 93
12	Retainer	Left	1	3382 0104 94
13	Bushing		2	3382 0104 95
14	Lock washer		2	4700 9009 94
15	Nut	M12	2	-
16	Clamp		2	3382 0104 96
17	Screw	M12 x 40 mm 8.8 A3K	4	-
18	Washer	13 x 24 x 6 mm 0.51 x 0.95 x 0.16 in. 300 HV	8	-
19	Lock nut	M12	4	-
20	Hook		1	4700 2827 24
21	Ball knob		1	4700 2813 82
22	Nut	M10	1	-
23	Washer	10.5 x 22 x 4 mm 0.41 x 0.87 x 0.16 in. 300 HV	2	-
24	Shock absorber		1	4700 2814 31
25	Nut	M10 A3K	1	-
26	Screw	M8 x 16 mm 8.8 A2K	8	-
27	Washer	8.4 x16 x1.5 mm 0.33 x 0.63 x 0.06 in. 300 HV	8	-
28	Screw	M5 x 16 mm	2	-
29	Ryw-clips		2	4700 2811 16
30	Oil drain, complete		1	4700 2818 52
31	Hose		1	4700 2440 59
32	Rubber strip	220 mm 8.66 in.	1	4700 9269 11
33	Spirol pin		2	4700 6290 59

Throttle control

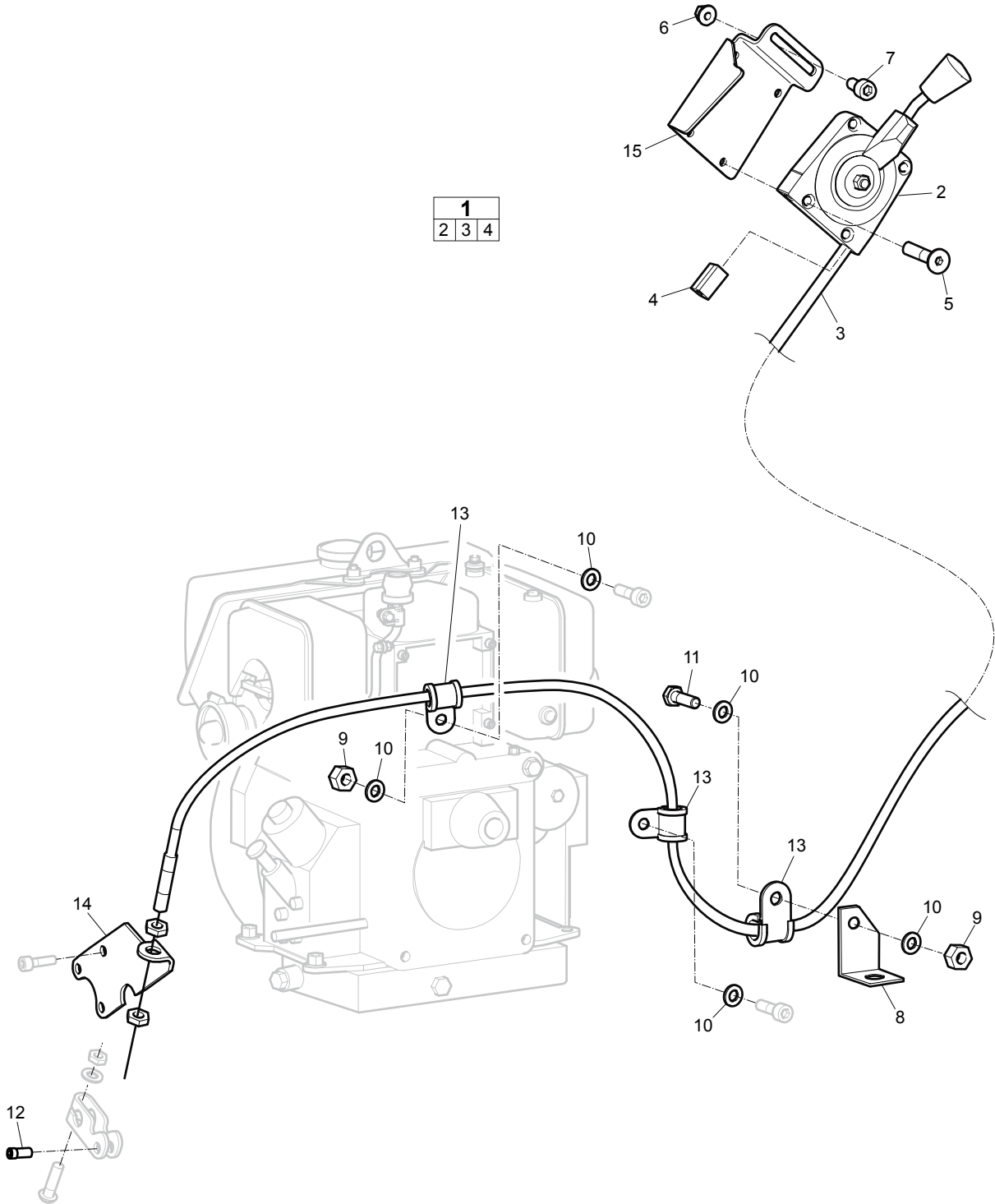

No.	Description	Remark	Quantity	Part number
1(2-4)	Throttle control, complete		1	4700 3974 92
2	Throttle handle		1	4700 4550 19
3	Control cable		1	4700 3807 51
4	Square nipple		1	4700 2384 43
5	Screw	M5 x 30 mm A2-70	4	-
6	Nut	M6 x 1 mm A2K	1	4700 9022 85
7	Screw	M6 x 20 mm 8.8 A2K	1	-
8	Bracket		1	4700 2827 07
9	Nut	M6 A2K	3	-
10	Washer	6.4 x 12 x 1.5 mm 0.25 x 0.47 x 0.06 in. 300 HV	6	-
11	Screw	M6 x 20 mm 8.8 A2K	1	-
12	Nipple		1	4700 2812 36
13	Clamp		3	4700 9210 65
14	Bracket		1	4700 2812 28
15	Bracket		1	4812 0701 15

Labels

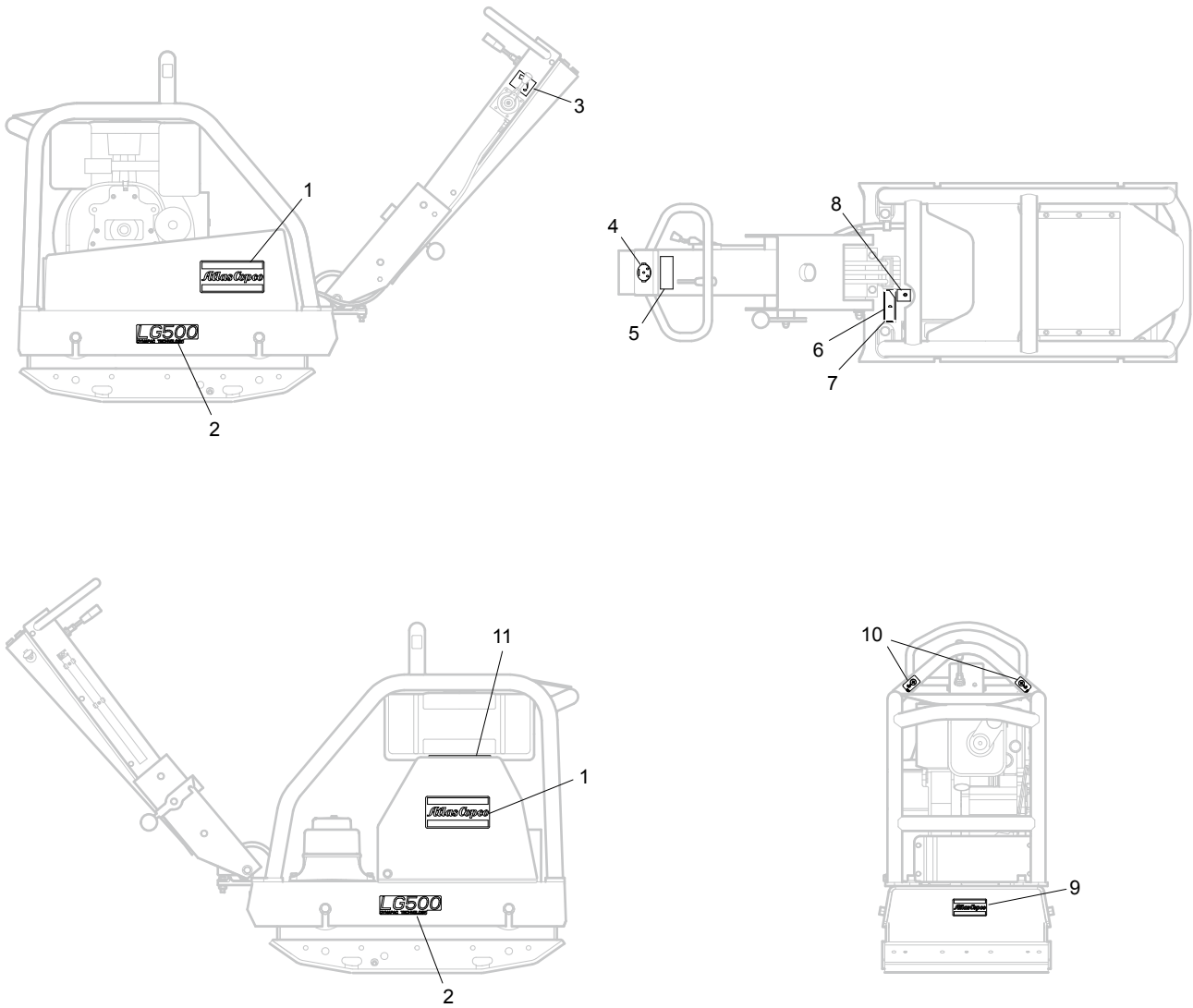

No.	Description	Remark	Quantity	Part number
1	Product label	"Atlas Copco"	2	3382 0100 22
2	Product label	"LG 500"	1	3382 0104 97
3	Label	Engine speed	1	4700 2842 85
4	Label	Ear protection	1	4700 2818 98
5	Label	Read instruction manual	1	4700 9046 80
6	Data plate		1	-
7	Drive screw		4	-
8	Label	Sound power level	1	4700 7912 97
9	Product label	"Atlas Copco"	1	3382 0100 79
10	Label	Lift point	2	4700 3575 87
11	Safety label	Rotating V-belts	1	4700 9038 32

Kits

One year service kit

One year service kit

Part number 3382 1000 28

Description	Remark	Quantity	Part number
Air filter		5	4700 2384 23
Fuel filter		5	4700 9378 73
Gasket	For oil drain plug.	1	4700 7484 79
V-belt	See section "Engine installation".	2	4700 3863 12
Gasket	For valve cover.	1	4700 2393 33
Oil filter		5	4700 2393 26

Shock absorber repair kit

Description	Remark	Quantity	Part number
Shock absorber repair kit		1	3382 1000 33
Shock absorber	For ground plate. See section "Ground plate and eccentric element installation".	4	4700 2804 54
Nut	M16 A3K See section "Ground plates and engine plate".	8	-
Washer	17 x 30 x 3 mm 0.70 x 1.18 x 0.12 in. 300 HV See section "Ground plates and engine plate".	8	-
Shock absorber	For handle. See section "Handle".	4	3382 0104 90
Screw	M10 x 16 mm 8.8 A3K See section "Handle".	8	-
Washer	10.5 x 22 x 2 mm 0.41 x 0.87 x 0.08 in. 300 HV See section "Handle".	8	-
Shock absorber	For handle. See section "Handle".	1	3382 0104 92
Screw	M12 x 40 mm 8.8 A3K See section "Handle".	4	-
Washer	13 x 24 x 6 mm 0.51 x 0.95 x 0.16 in. 300 HV See section "Handle".	8	-
Nut	M12 See section "Handle".	4	-
Shock absorber	For hook. See section "Handle".	1	4700 2814 31
Spirol pin	12 x 50 mm 0.47 x 1.97 in See section "Handle".	2	4700 6290 59
Washer	10.5 x 22 x 4 mm 0.41 x 0.87 x 0.16 in. 300 HV See section "Handle".	1	-
Nut	M10 See section "Handle".	1	-

Eccentric element repair kit

Description	Remark	Quantity	Part number
Eccentric element repair kit		1	3382 1000 37
Sealing	See section "Eccentric element".	1	4700 9287 94
Ball bearing	See section "Eccentric element".	4	4700 9287 86
Washer	6.4 x 12 x 1.5 mm 0.25 x 0.47 x 0.06 in. 300 HV See section "Eccentric element".	16	-
Screw	M6 x 20 mm 8.8 A2K See section "Eccentric element".	16	-
Copper washer	16.7 x 24 x 1.5 mm 0.66 x 0.94 x 0.06 in. TYPE A, M16 See section "Eccentric element".	1	-
Retainer ring	See section "Eccentric element".	1	4700 9287 87
Sealing compound		1	4700 9299 06
Ball bearing	See section "Eccentric element".	2	4700 9287 96

Forward and reverse piston repair kit

Description	Remark	Quantity	Part number
Forward and reverse piston repair kit		1	3382 1000 35
Sealing	See section "Eccentric element".	1	4700 2812 76
Piston rod	See section "Eccentric element".	1	4812 0700 44
Retainer ring	See section "Eccentric element".	1	4700 1510 39
Ball bearing	See section "Eccentric element".	1	4812 0703 59
Retainer ring	See section "Eccentric element".	1	4700 1500 02
Ball bearing	See section "Eccentric element".	1	4812 0703 62
Spring washer	See section "Eccentric element".	1	4812 0703 63
Cylinder	See section "Eccentric element".	1	4812 0700 42
Spirol pin	See section "Eccentric element".	1	4700 6290 62
Washer	6.4 x 12 x 1.5 mm 0.25 x 0.47 x 0.06 in. 300 HV See section "Eccentric element".	4	-
Screw	M6 x 20 mm 8.8 A2K See section "Eccentric element".	4	-

Block paving plate kit 750 mm (29.5 in.)

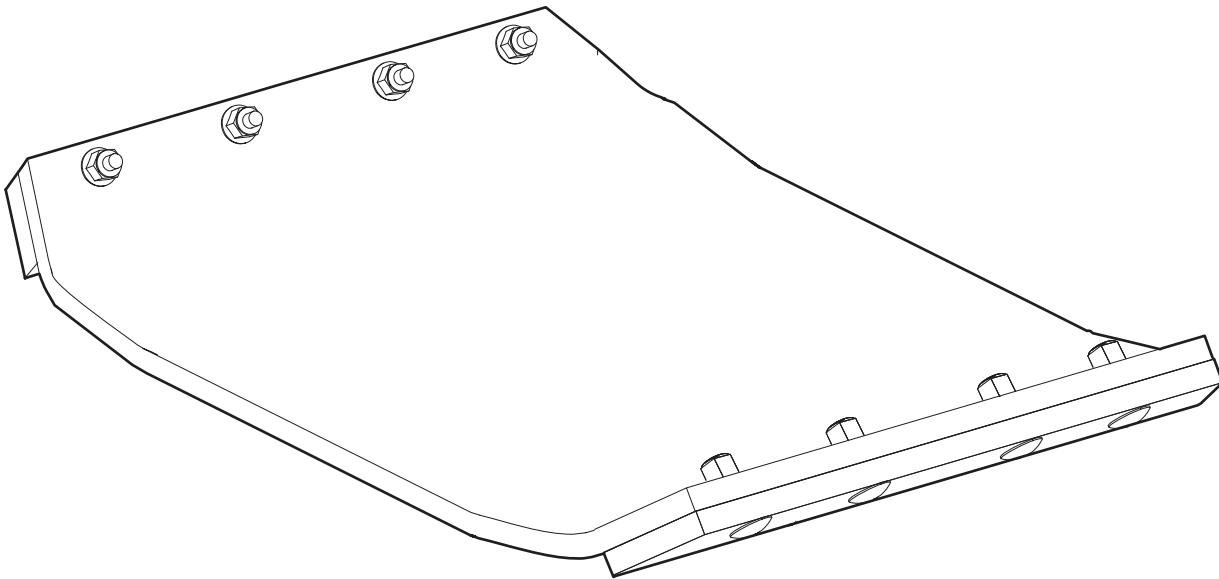

Description	Remark	Quantity	Part number
Block paving plate kit		1	4700 3820 01
Polyurethane plate	750 mm 29.5 in.	1	-
Bracket		2	-
Nut	M10 x 1.5 mm A3K	8	-
Screw	M10 x 45 mm 4.6 A3K	8	-

Block paving plate kit 850 mm (33.5 in.)

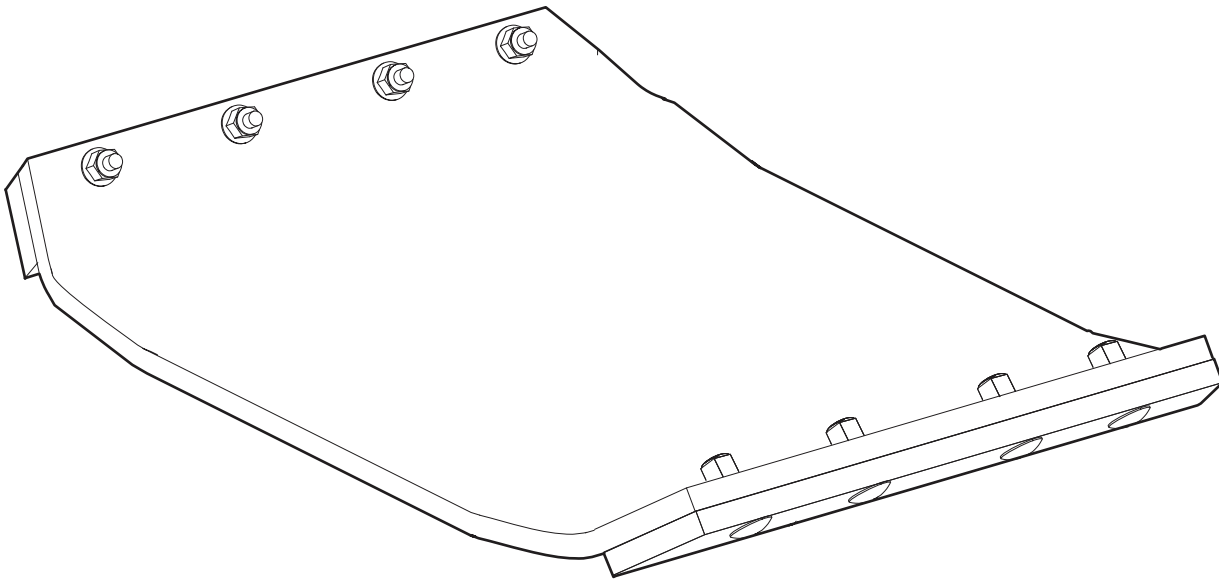

Description	Remark	Quantity	Part number
Block paving plate kit		1	4700 3820 05
Polyurethane plate	850 mm 33.5 in.	1	-
Bracket		2	-
Nut	M10	8	-
Screw	M10 x 50 mm 8.8 A3K	8	-
Washer	10.5 x 22 x 2 mm 0.41 x 0.87 x 0.08 in. 300 HV	8	-

Extension plate kit 2 x 75 mm (2 x 2.95 in.)

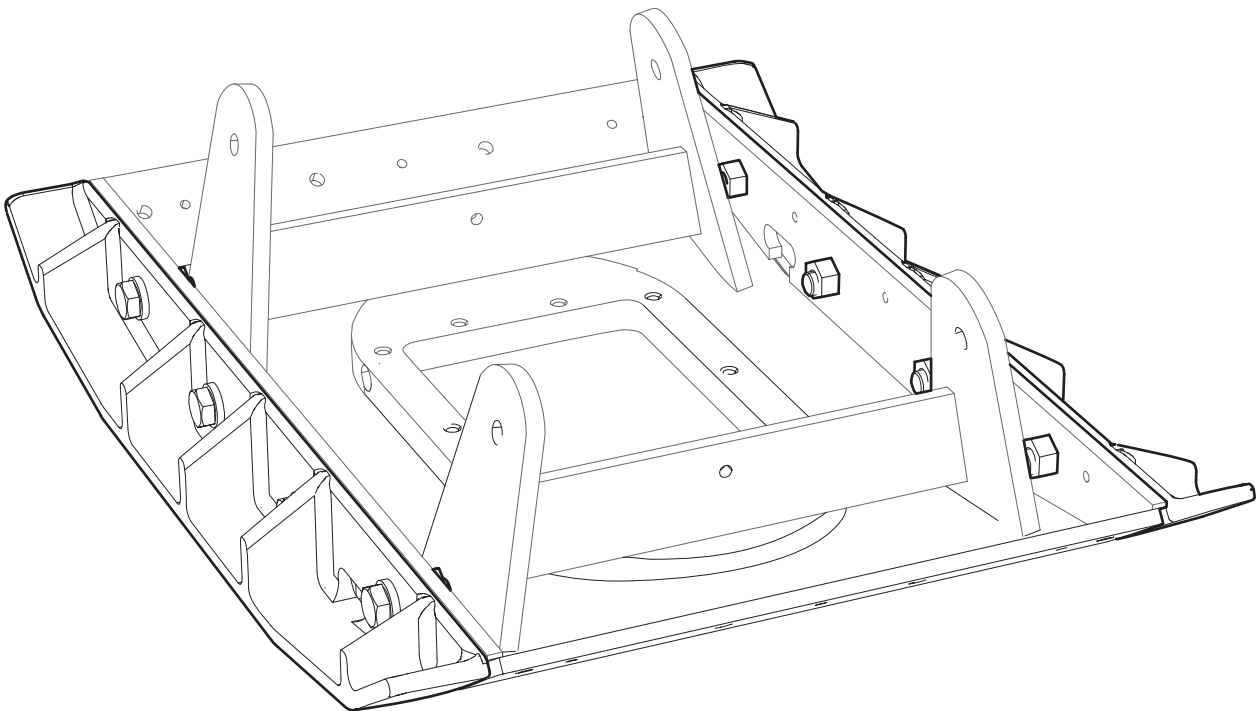

Description	Remark	Quantity	Part number
Extension plate kit 2 x 75 mm (2 x 2.95 in.)		1	4812 0706 78
Extension plate	75 mm 2.95 in.	2	-
Washer	21 x 36 x 6 mm 0.83 x 1.42 x 0.24 300 HV	8	-
Screw	M20 x 50 mm 8.8 A9K	8	-

Extension plate kit 2 x 150 mm (2 x 5.90 in.)

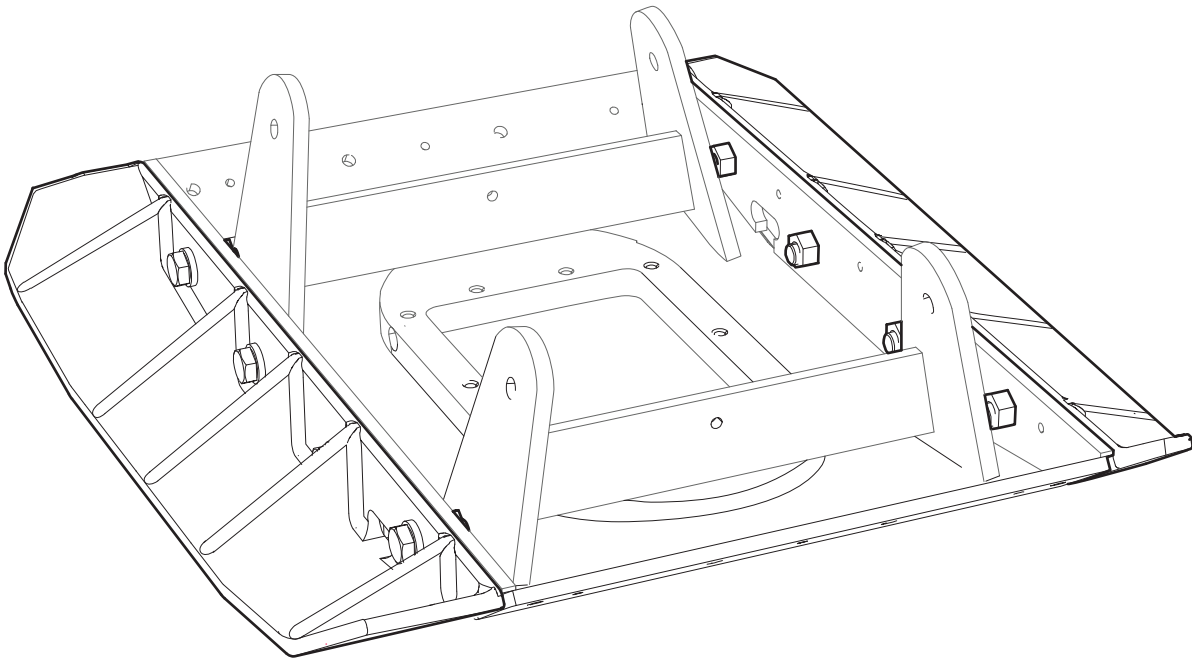

Description	Remark	Quantity	Part number
Extension plate kit 2 x 150 mm (2 x 5.90 in.)		1	4700 3820 67
Extension plate	150 mm 5.90 in.	2	-
Screw	M20 x 50 mm 8.8 A9K	8	-
Washer	21 x 45 mm 0.83 x 0.87 x 1.77 in. 300 HV	8	-

Slanted extension plate kit 2 x 150 mm (2 x 5.90 in.)

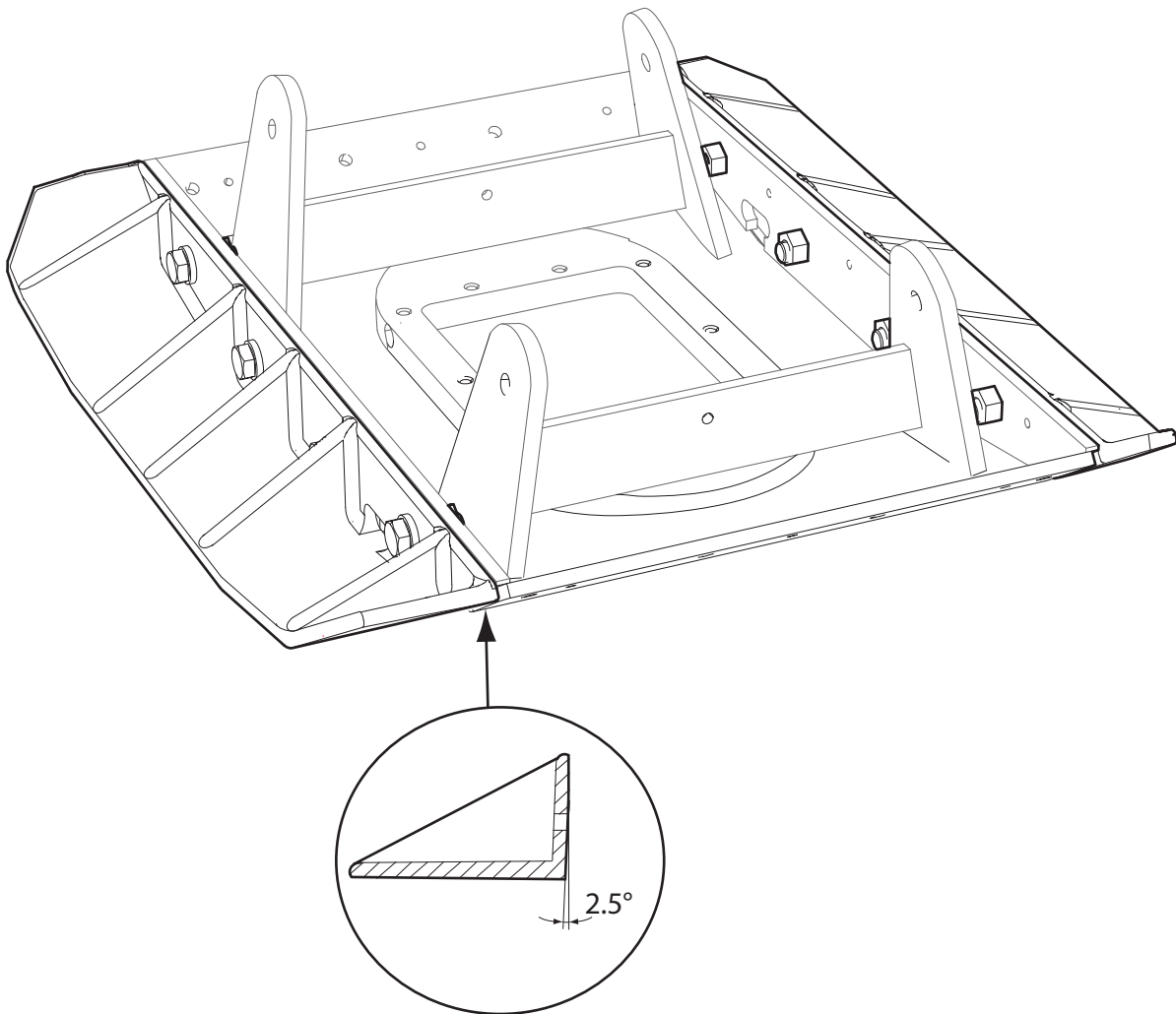

Description	Remark	Quantity	Part number
Slanted extension plate kit 2 x 150 mm (2 x 5.90 in.)		1	4700 3820 68
Extension plate	150 mm 5.90 in. Slanted 2.5°	2	-
Screw	M20 x 50 mm 8.8 A9K	8	-
Washer	21 x 45 mm 0.83 x 0.87 x 1.77 in. 300 HV	8	-

Hour meter kit

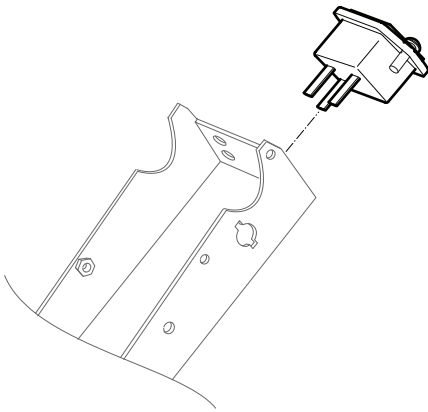

Description	Remark	Quantity	Part number
Hour meter kit		1	4700 3769 34
Hour meter		1	-
Screw	M3 x 10 mm 8.8 A2-70	2	-
Nut	M3 A2K	2	-

Safety crank handle kit

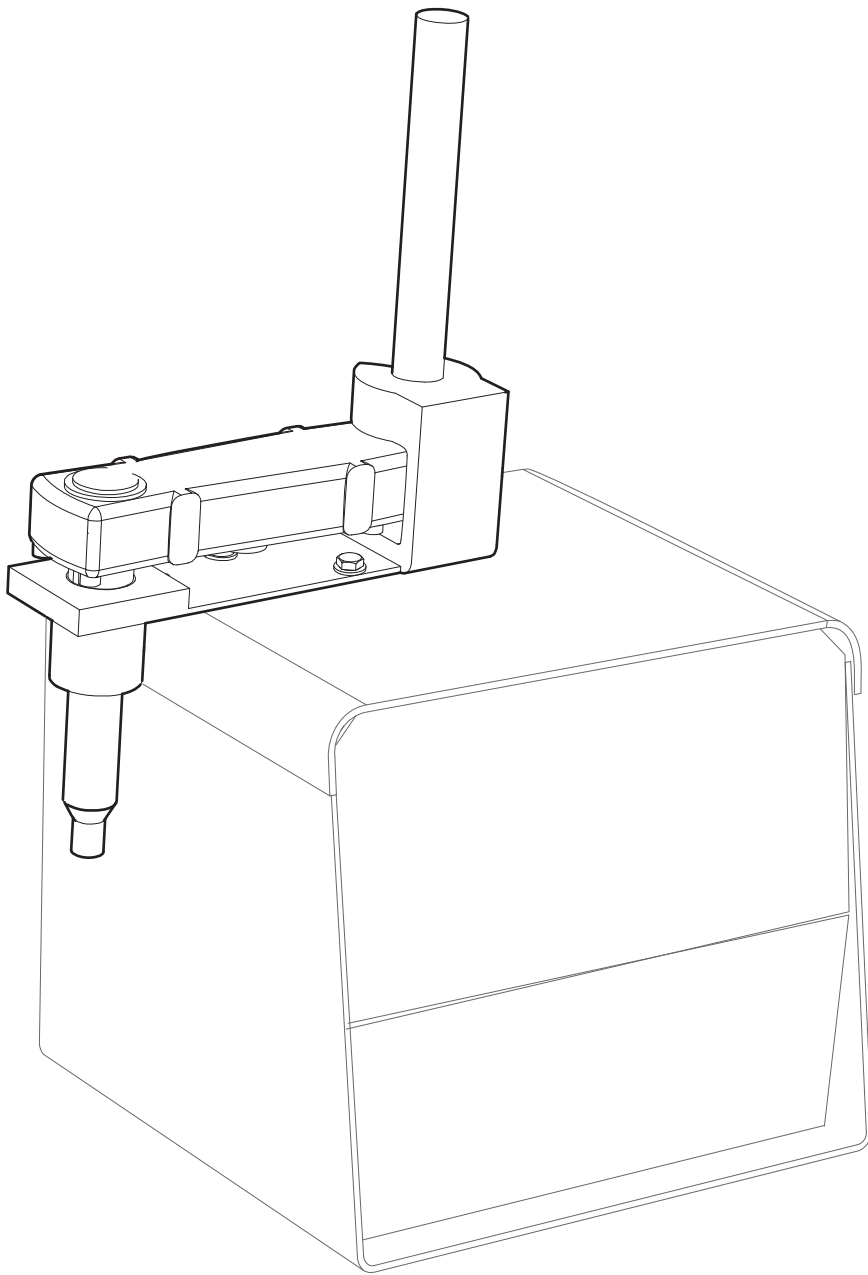

Description	Remark	Quantity	Part number
Safety crank handle kit		1	4700 2837 74
Safety crank		1	-
Crank holder		1	-
Screw		2	-
Nut		2	-
Washer		2	-



MASKINSALG ^{A/S}
UTSTYR FOR INDUSTRI OG ANLEGG
Blindheimsveien 1, 5131 Nyborg
www.maskinsalg.com
SALG - SERVICE - UMLEIE Tlf. 55 19 96 20

Any unauthorized use or copying of the contents or any part thereof is prohibited.
This applies in particular to trademarks, model denominations, part numbers, and drawings.

© 2011 Atlas Copco Construction Tools AB | No. 9800 1112.01 | 2011-04-01

Atlas Copco

www.atlascopco.com