

Spare Parts List

**MASTER**

**PROLINE**

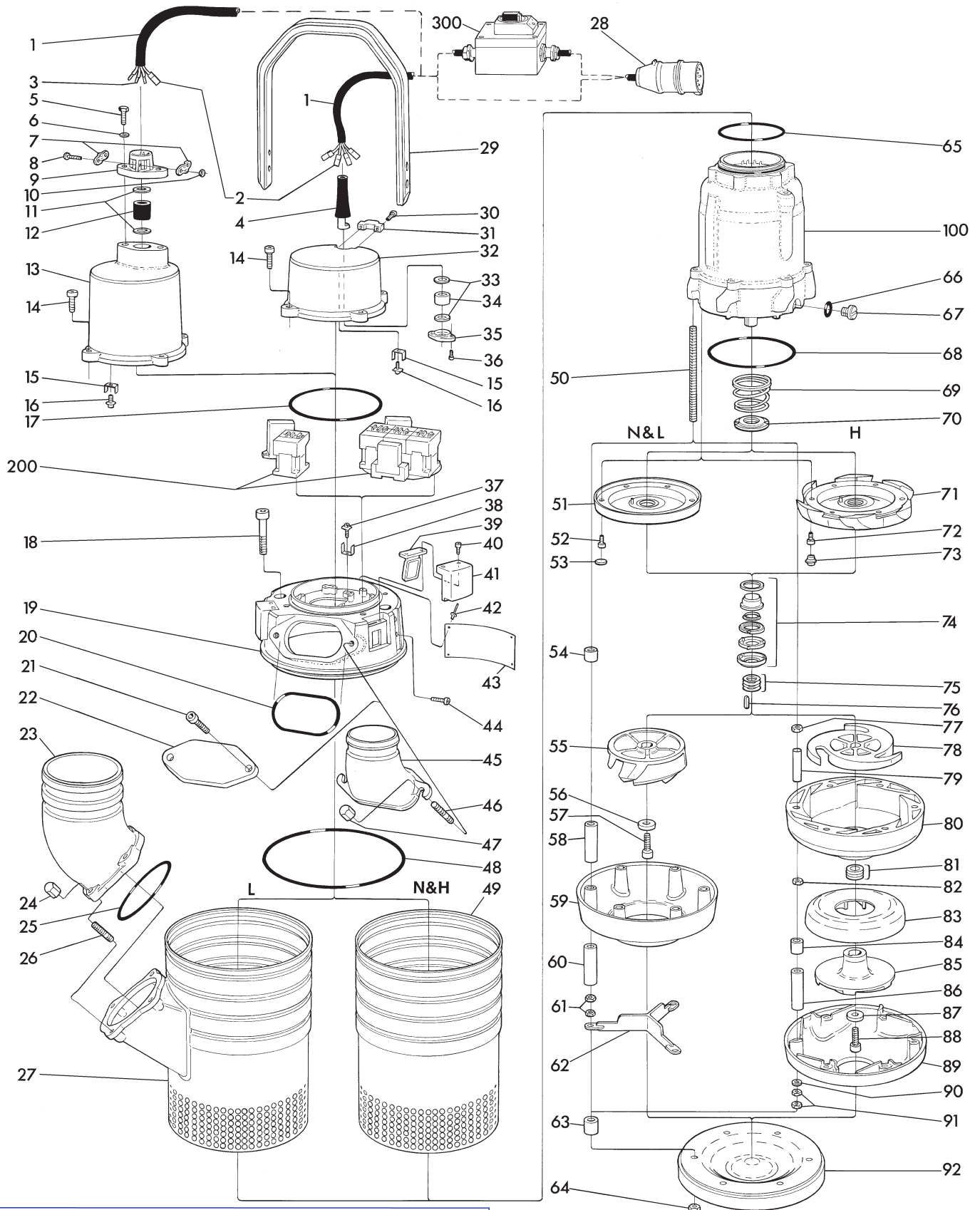

**MASKINSALG A/S**  
 UTSTYR FOR INDUSTRI OG ANLEGG  
 Blindheimsveien 1, 5131 Nyborg  
 www.maskinsalg.com  
 SALG - SERVICE - UITLEIE Tlf. 55 19 96 20

Motorenhet

Motor unit

Motoreinheit

Moteur complet

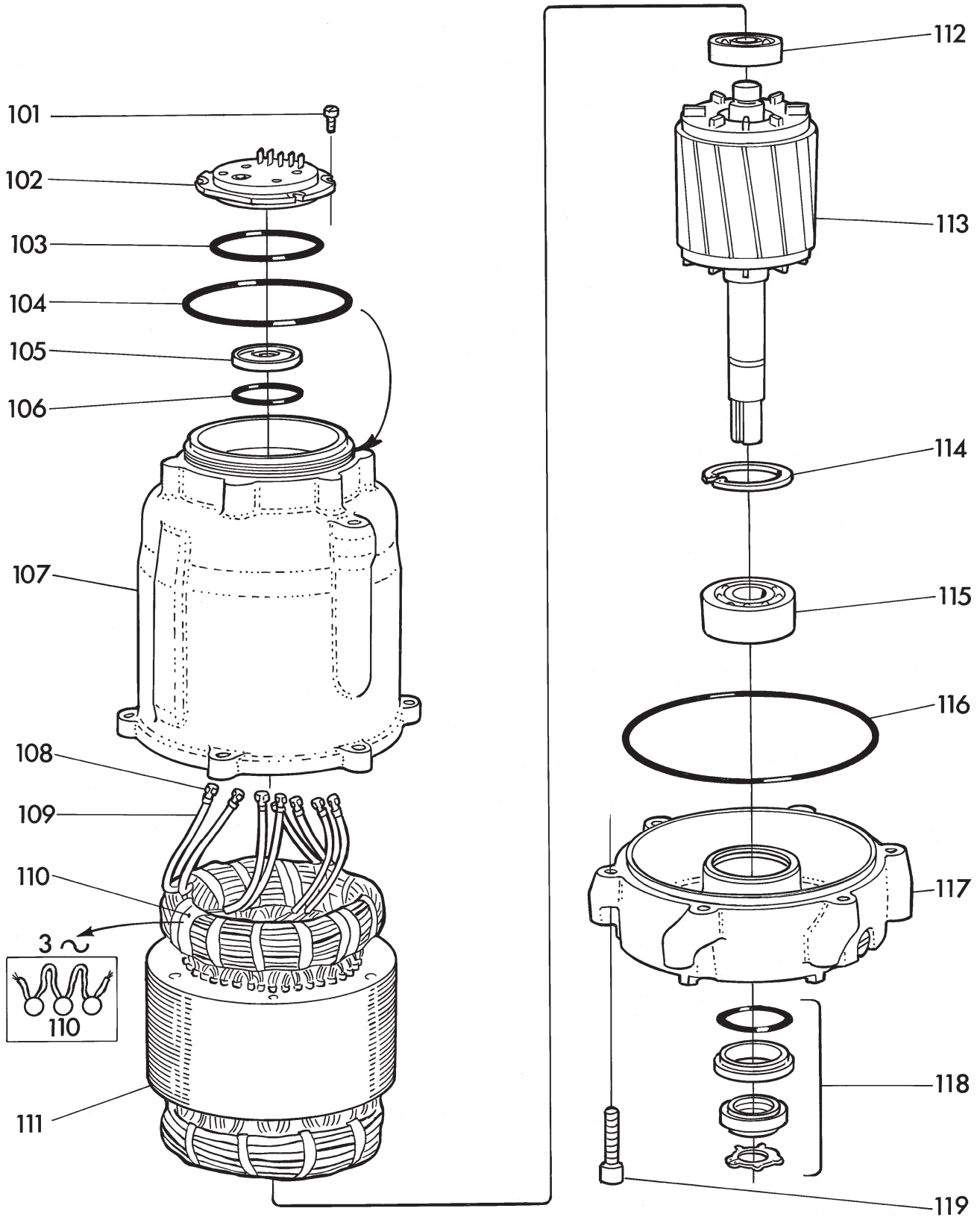

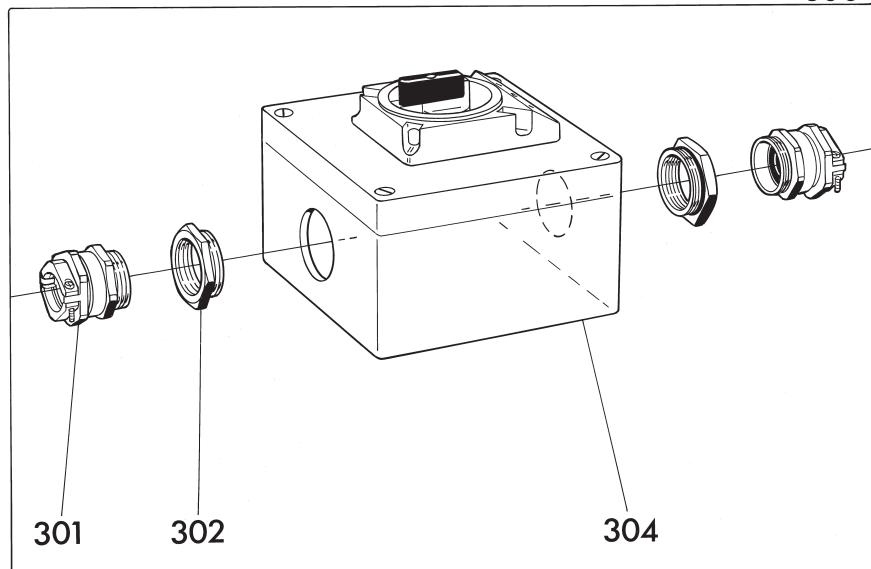
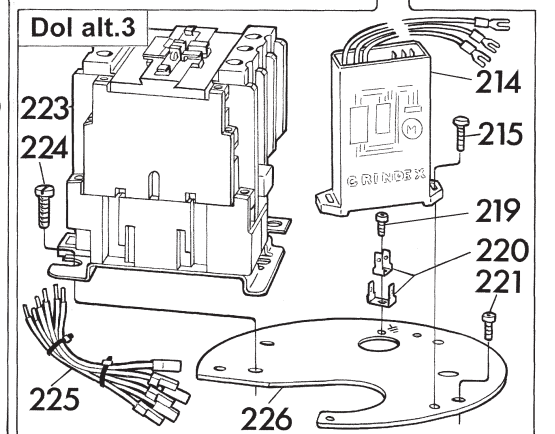
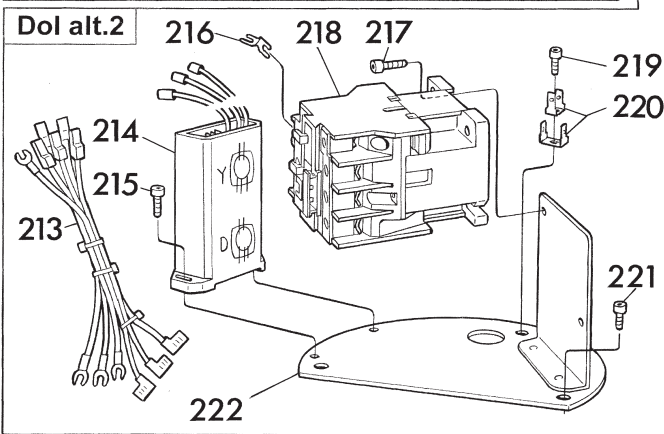
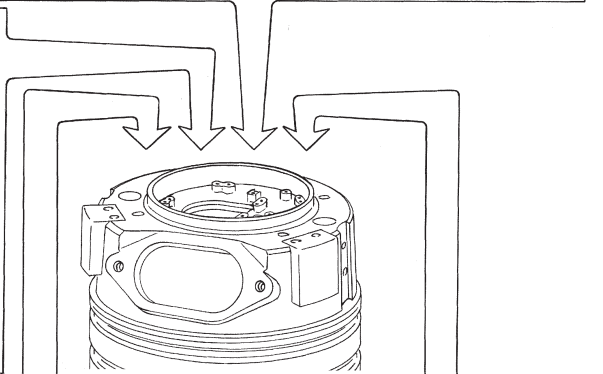
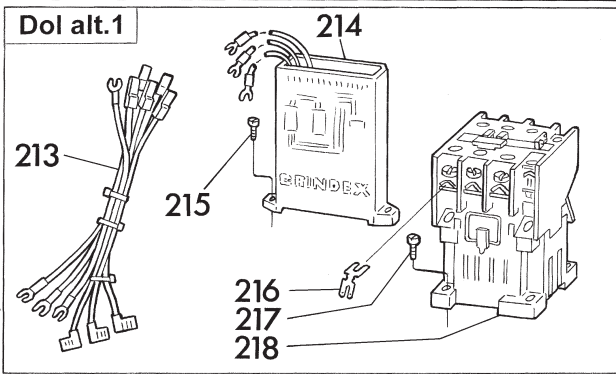
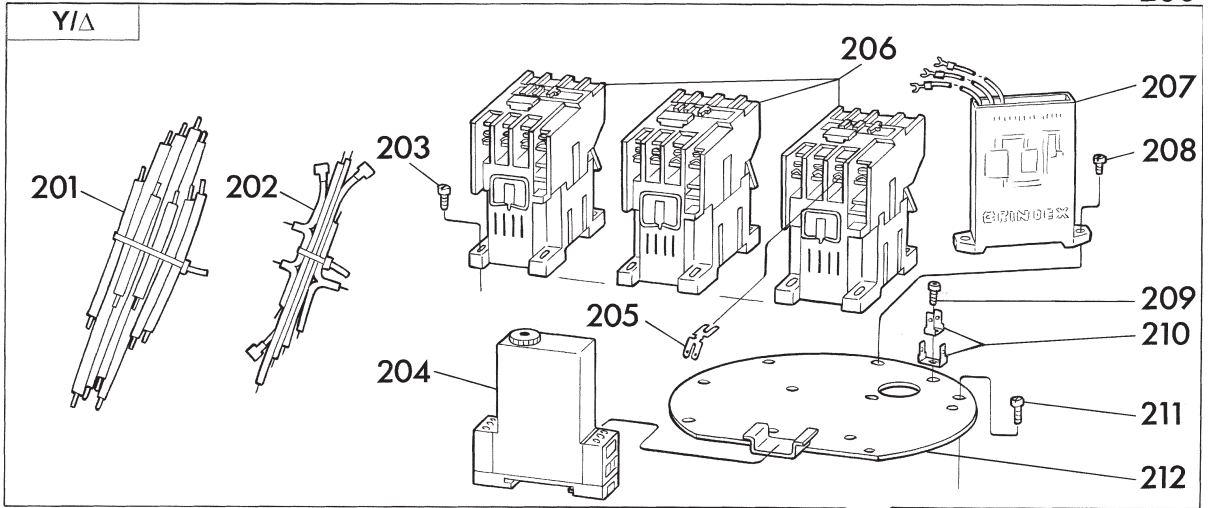

Reservdelslista	Spare Parts List	Ersatzteilliste	Liste des pièces de rechange
<b>Master N Type G35xx</b>	<b>Master H Type G36xx</b>	<b>Master L Type G37xx</b>	
N= Normalutförande Regular version Normalausführung Version normale	H= Högtrycksutförande High Head version Hochdrucksausführung Version haute pression	L= Lågtrycksutförande Large capacity version Ausführung für grosse Fördermenge Version grand débit	

Y/D	DOL alt.1	DOL alt.2	DOL alt.3
346-460V	500-575V	346-460V	200-230V

PU	GU	RF	ST	VJ	FZ	AL	ZA
Polyurethan Polyurethane Polyurethan Polyuréthane	Gummi Rubber Gummi Caoutchouc	Rostfritt stål Stainless steel Rostfreier Stahl Acier inoxydable	Stål Steel Stahl Acier	Vitjäm White iron Chromlegerter Hartguss Fonte blanche alliée au chrom	Förzinkad Galvanized Galvanisiert Galvanisé	Aluminium Aluminum Aluminium Aluminium	Zinkanoder Zinc anodes Zinkanoden Anodes sacrificielles

Pos. nr. Item No. Pos-Nr No. de repérage	Detailnr. Part No. Bestell-Nr. No de pièce	Benämning	Denomination	Bezeichnung	Désignation	Antal Quantity Anzahl Nombre
1		Kabel inkl pos 2, (3, 4)	Cable incl items 2, (3, 4)	Kabel einschl. Pos. 2, (3, 4)	Câble avec No. de rep. 2, (3, 4)	1
	50 143 10	4x2,5mm <sup>2</sup> (H07RN-F Ø12,1-15,5) 20m		380-550V/50Hz & 400-575V/60Hz		
	50 143 11	4x4mm <sup>2</sup> (H07RN-F Ø14-17,9) 20m		346V/50Hz & 380V/60Hz		
	50 143 15	4x6mm <sup>2</sup> (H07RN-F Ø15,7-20) 20m		200-220V/50Hz & 230V/60Hz		
		Gäller upp till 20m längd. Vid annan längd kontakta Grindex.	Refers to length of 20m. For other lengths please contact Grindex.	Bezieht sich auf Länge von 20 Metern. Für andere Längen bitte fragen Sie Grindex.	Concernant longueur de 20 metres. Pour autres longueurs consultez Grindex.	
2		Flatsstiftshylsa	Receptacle	Steckhülse	Clip	1-4
	50 040 03	1,5-2,5mm <sup>2</sup>				
	50 040 08	4-6mm <sup>2</sup>				
3	50 221 04	Ändhylsa för ledare	Sleeve for conductor	Hülse für Leiter	Douille pour fil	DOL alt.3=3
4		Kabelböjskydd	Cable entry sleeve	Hülse für Kabeleinführung	Douille d'entrée de câble	1
	50 428 01	För Ø12-13,8mm	For Ø12-13,8mm	Für Ø12-13,8mm	Pour Ø12-13,8mm	
	50 428 02	För Ø13,8-15,8mm	For Ø13,8-15,8mm	Für Ø13,8-15,8mm	Pour Ø13,8-15,8mm	
	50 428 03	För Ø16-18mm	For Ø16-18mm	Für Ø16-18mm	Pour Ø16-18mm	
5	50 021 00	Skruv M8x25	Screw	Schraube	Vis	DOL alt.3=2
6	132 289	Bricka	Washer	Scheibe	Rondelle	DOL alt.3=2
7	50 216 00	Klamma	Clamp	Klammer	Pince	DOL alt.3=2
8	131 961	Skruv M5x25	Screw	Schraube	Vis	DOL alt.3=2
9	50 213 00	Införingsfläns	Flange	Flansche	Bride	DOL alt.3=1
10	131 402	Mutter	Nut	Mutter	Ecrou	DOL alt.3=2
11		Tätningbricka, för kabel:	Washer, for cable:	Scheibe, für Kabel:	Rondelle, pour câble:	DOL alt.3=2
	50 016 11	Ø16-18mm (Ø0.63-0.71in)				
12		Gummikuts, för kabel:	Rubber seal, for cable:	Gummidichtung, für Kabel:	Manchon, pour câble	DOL alt.3=1
	50 015 08	Ø16-18mm (Ø0.63-0.71in)				
13	50 429 00	Lock DOL 200-230V	Cover	Deckel	Couvercle	DOL alt.3=1
14	132 395	Skruv M8x20	Screw	Schraube	Vis	4
15	50 119 00	Flatsstiftsbleck	Tab	Steckverbindung	Languette	1
16	50 018 01	Skruv M 4x8	Screw	Schraube	Vis	1
17	50 037 00	O-ring 160x6.0	O-ring	O-Ring	Anneau torique	1
18	50 023 00	Skruv M 12x70	Screw	Schraube	Vis	2
19	50 008 00	Överdel	Main cover	Hauptdeckel	Couvercle principal	1
20	131 656	O-ring 104.14x5.34	O-ring	O-Ring	Anneau torique	1
21	130 965	Skruv M10x35	Screw	Schraube	Vis	L=2
22	131 786	Inspektionsslucka	Inspection cover	Inspektionsdeckel	Couvercle de inspection	L=1

Item No.	Part No.	Benämning	Denomination	Bezeichnung	Désignation	Quantity
23		Tryckanslutning	Discharge connection	Druckanschluss	Coude de refoulement	L=1
	<b>L</b>					
	130 729	6"				
	131 103	R6" BSP female				
	50 352 00	NPT 6-8 female				
24	140 089	Mutter M 10	Nut	Mutter	Ecrou	L=4
25	130 944	O-ring 149,3x5,7	O-ring	O-Ring	Anneau torique	L =1
26	130 731	Pinnskruv M10x45	Stud	Stiftschraube	Goujon	L=4
27	50 062 10	Mantel L (RF)	Outer casing	Aussenmantel	Enveloppe ext.	L=1
28		Europahandske	Euro plug	Euro-Verdinder	Euro connecteur	(1)
	50 100 01	CEE 432-6 (380-400V/50Hz)				
	50 100 10	CEE 316-7 (500V/50Hz)				
	50 100 11	CEE 332-7 (500V/50Hz)				
29	50 014 00	Handtag	Handle	Griff	Poignée	1
30	50 019 00	Skruv M5x18	Screw	Schraube	Vis	2
31	50 011 00	Kabelavlastning	Cable clamp	Zugentlastung	Collier	1
32	50 002 04	Lock	Cover	Deckel	Couvercle	1
33		Tättningsbricka, för kabel:	Washer, for cable:	Scheibe, für Kabel:	Rondelle, pour câble:	2
	50 016 01	Ø12-14mm (Ø0.47-0.55in)				
	50 016 02	Ø14-16mm (Ø0.55-0.63in)				
	50 016 03	Ø16-18mm (Ø0.63-0.71in)				
34		Gummikut, för kabel:	Rubber seal, for cable:	Gummidichtung, für Kabel:	Manchon, pour câble	1
	50 015 01	Ø12-14mm (Ø0.47-0.55in)				
	50 015 02	Ø14-16mm (Ø0.55-0.63in)				
	50 015 03	Ø16-18mm (Ø0.63-0.71in)				
35	50 017 01	Införingsfläns	Cable entry flange	Kabeleinführungsflansch	Bride d'entrée de câble	1
36	50 019 00	Skruv M5x18	Screw	Schraube	Vis	2
37	133 525	Skruv	Screw	Schraube	Vis	1
38		Flatsiftsbleck	Tab	Flachstecker	Ian guette	1
	50 119 00	DOL alt.1				
	50 119 01	Y/D & DOL alt.2, alt.3				
39	50 013 00	Ventil	Valve	Ventil	Soupape	2
40	50 019 00	Skruv M 5x18	Screw	Schraube	Vis	4
41	50 012 00	Ventillock	Valve cover	Ventildeckel	Couvercle de soupape	2
42	50 139 00	Popnit	Rivet	Niet	Rivet	4
43	50 010 05	Dataskylt, ostämpl.	Data plate, blank	Datenschild, ungepr.	Plaque signal. vide	1
44	50 021 00	Skruv M8x25	Screw	Schraube	Vis	4
45		Tryckanslutning	Discharge conn.	Druckanschluss	Coude de refoulement	N&H=1
	<b>H</b>		<b>N</b>			
	132 178	3"	131 569	4"		
	132 527	R 3" W BSP male	131 839	R 4" W BSP male		
	50 349 00	NPT 3"-8 male	50 187 02	NPT 4"-8 male		
46	130 731	Pinnskruv M10x45	Stud	Stiftschraube	Goujon	N&H=2
47	140 089	Mutter M10	Nut	Mutter	Ecrou	N&H=2
48	140 075	O-ring 259.3x3	O-ring	O-Ring	Anneau torique	1
49		Mantel	Outer casing	Aussenmantel	Enveloppe ext	N&H=1
N	50 062 06					
H	50 062 09					
50	50 022 09	Pinnskruv M10x185	Stud	Stiftschraube	Goujon	6
51	50 578 03	Diffusor, övre	Diffuser, upper	Diffusor, oberer	Diffuseur, supérieur	N&L=1
52	140 049	Skruv M8x16	Screw	Schraube	Vis	N&L=6
53	140 114	Skyddsbricka	Washer	Scheibe	Rondelle	N&L=6
54		Gummikut	Rubber seal	Gummidichtung	Manchon	
	50 316 01	15mm (0,6in)			N=6(12) & L50Hz=12	
	50 316 02	20mm (0,8in)			N=6(12) & L60Hz=6	

Item No.	Part No.	Benämning	Denomination	Bezeichnung	Désignation	Quantity
55		Pumphjul	Impeller	Laufgrad	Turbine	N&L=1
	<b>50Hz</b>		<b>60Hz</b>			
N	50 265 00	Ø146 (5.75") VJ	50 265 01	Ø126 (4.96")VJ		
N	50 265 02	Ø146 (5.75") RF	50 265 03	Ø126 (4.96") RF		
L	50 264 00	Ø115.6 (4.55") VJ	50 377 00	Ø124 (4.88") VJ		
L	50 264 02	Ø115.6 (4.55") RF				
56	133 147	Bricka	Washer	Scheibe	Rondelle	N&L=1
57	133 148	Skruv	Screw	Schraube	Vis	N&L=1
58	50 317 02	Distansrör (14x11x57)	Spacer tube	Distanzrohr	Tube d'espacement	N&L=6
59		Diffusor, undre	Diffuser, lower	Diffusor, unterer	Diffuseur, inférieur	N&L=1
N&L	50 321 01	GU+RF				
N&L	50 321 03	PU+RF				
60	50 317 00	Distansrör (14x11x33)	Spacer tube	Distanzrohr	Tube d'espacement	N&L=6
61	130 955	Mutter M10	Nut	Mutter	Ecrou	N&L=12
62	50 319 00	Virveldämpare	Swirl damper	Wirbeldämpfer	Dompteu	N&L=1
63	50 316 01	Gummikuts	Rubber seal	Gummidichtung	Manchon	N50&60, H50, L50=6
	50 316 02	Gummikuts	Rubber seal	Gummidichtung	Manchon	H60, L60=6
64	50 131 00	Mutter M10	Nut	Mutter	Ecrou	6
65	140 071	O-ring 117,5x5,34	O-ring	O-Ring	Anneau torique	1
66	140 077	O-ring 12.37x2.62	O-ring	O-Ring	Anneau torique	1
67	140 034	Oljeskruv	Oil screw	Ölschraube	Vis d'huile	1
68	140 078	O-ring 156x3	O-ring	O-Ring	Anneau torique	1
69	50 559 01	Fjäder	Spring	Feder	Ressort	1
70	50 573 00	Tryckplatta	Thrust plate	Druckscheibe	Rondelle	1
71		Diffusor, övre	Diffuser, upper	Diffusor, oberer	Diffuseur, supérieur	H=1
H	50 578 04	GU+RF				
H	50 578 05	PU+RF				
72	140 049	Skruv M8x16	Screw	Schraube	Vis	H=6
73	133 060	Skyddsbricka	Washer	Scheibe	Rondelle	H=6
74	50 420 00	Axeltätningssats, undre	Shaft seal kit, lower	Wellendichtung, unt.,Satz	Joint mécanique, inf. jeu	1
75	140 026	Justerbricka	Adjusting washer	Justierscheibe	Rondelle de réglage	5-11
76	50 205 05	Plattkil (5x5x35)	Key	Keil	Clavette	1
77	50 022 11	Mutter M10	Nut	Mutter	Ecrou	H=6
78		Pumphjul	Impeller	Laufgrad	Turbine	H=1
	<b>50Hz</b>		<b>60Hz</b>			
H	133 197	Ø192mm (7.6in) VJ	50 266 00	Ø180mm (7.1in) VJ		
H	133 197RF	Ø192mm (7.6in) RF	50 266 02	Ø180mm (7.1in) RF		
79	50 317 01	Distansrör (14x11x48,5)	Spacer tube	Distanzrohr	Tube d'espacement	H=6
80		Diffusor, undre	Diffuser, lower	Diffusor, unterer	Diffuseur, inférieur	H=1
H	50 320 05	GU+RF				
H	50 320 07	PU+RF				
81	50 343 00	Justerbricka	Adjusting washer	Justierscheibe	Rondelle de réglage	H=5-11
82	130 955	Mutter M10	Nut	Mutter	Ecrou	H=6
83		Ledskeneskiva	Diffuser disc	Diffusorscheibe	Disque	H=1
H	50 332 01	GU+RF				
H	50 332 02	PU+RF				
84	50 316 01	Gummikuts	Rubber seal	Gummidichtung	Manchon	H=6
85		Pumphjul	Impeller	Laufgrad	Turbine	H=1
	<b>50Hz</b>		<b>60Hz</b>			
H	50 260 00	VJ	50 260 01	VJ		
H	50 260 02	RF	50 260 03	RF		
86	50 317 00	Distansrör (14x11x33)	Spacer tube	Distanzrohr	Tube d'espacement	H=6
87	133 147	Bricka	Washer	Scheibe	Rondelle	H=1
88	50 022 12	Skruv M10x40	Screw	Schraube	Vis	H=1

Item No.	Part No.	Benämning	Denomination	Bezeichnung	Désignation	Quantity
89		Diffusor, undre	Diffuser, lower	Diffusor, unterer	Diffuseur, inférieur	H=1
H	50 141 04	GU+RF				
H	50 141 06	PU+RF				
90	50 022 30	Bricka	Washer	Scheibe	Rondelle	H=6
91	130 955	Mutter M10	Nut	Mutter	Ecrou	H=12
92		Bottenplatta	Strainer bottom	Siebboden	Fond de crépine	1
	50 005 00	AL				
	140 012	FZ				
	140 012RF	RF				
	131 345	FZ+ZA				
100	Motorenhet	Motor unit	Motoreinheit	Moteur complet		(1)
101	140 494	Skruv M8x10	Screw	Schraube	Vis	4
102		Kopplingsplint	Terminal board	Klemmenbrett	Plaque à bornes	1
	50 009 00	DOL				
	50 009 02	Y/D, DOL alt.3 & DOL alt.2: 230/460V 9-leads				
103	130 623	O-ring 74.61x3.53	O-ring	O-Ring	Anneau torique	1
104	50 037 01	O-ring 119.5x3	O-ring	O-Ring	Anneau torique	1
105	140 326	Täcklock	Protection cover	Schutzdeckel	Couvercle de protecteur	1
106	140 323	O-ring 47.63x3.53	O-ring	O-Ring	Anneau torique	1
107	50 082 05	Statorhus	Stator housing	Statorgehäuse	Logement de stator	1
108	50 040 03	Flatstiftshylsa	Receptacle	Steckhülse	Clip	8
109	50 079 01	Systoflexrör 50 mm	Insulating tube	Isolierschlauch	Gaine isolante	3
110	50 039 01	Termokontakt	Thermal contact	Thermokontakt	Contact thermique	1
111		Stator	Stator	Stator	Stator	1
	<b>50 Hz</b>		<b>60 Hz</b>			
	50 300 04	200/346V	50 300 13	220/380V		
	50 300 05	220/380V	50 300 14	230/460V, 9-leads		
	50 300 06	346/600V	50 300 17	380/660V		
	50 300 07	380-415/660-717V	50 300 07	460V D		
	50 300 09	500-550V D	50 300 16	575V D		
112	140 337	Kullager, övre	Ball bearing, upper	Kugellager, oberes	Roulement à billes sup.	1
113	50 302 00	Rotorenhet	Rotor unit	Rotoreinheit	Rotor complet	1
114	140 064	Låsring	Circlip	Nutring	Circlip	1
115	140 059	Kullager, nedre	Ball bearing, lower	Kugellager, unteres	Roulement à billes inf.	1
116	140 076	O-ring 188x3	O-ring	O-Ring	Anneau torique	1
117	50 545 00	Lagerhållare	Bearing holder	Lagerhalter	Logement de roulement	1
		Axeltätning, övre.	Shaft seal, upper.	Wellendichtung, ob.	Joint mécanique, sup.	1
118	50 534 00	Axeltätningssats, övre	Shaft seal kit, upper	Wellendichtung, ob.,Satz	Joint mécanique, sup. jeu	1
119	50 021 10	Skruv M8x40	Screw	Schraube	Vis	6
201	50 330 00	Huvudkabelsats Y/D	Supply cable set Y/D	Hauptkabelsatz Y/D	Jeu du câble principal Y/D	Y/D=1
202	50 331 00	Manöverkabelsats	Pilot cable set	Pilotkabelsatz	Jeu du câble de commande	Y/D=1
203	50 018 00	Skruv M4x12	Screw	Schraube	Vis	Y/D=6
204	50 148 02	Tidrelä	Time relay	Relais	Relais	Y/D=1
205	50 120 01	Flatsäftsbleck	Tab	Flachstecker	Languette	Y/D=3
206		Kontaktor	Contacteur	Kontaktor	Contacteur	Y/D=3
	<b>50Hz</b>		<b>60Hz</b>			
	50 353 13	346V	50 353 21	380V		
	50 353 09	380-415V	50 353 14	460V		
207		Motorskydd	Motor protector	Motorschutzschalter	Disjoncteur	Y/D=1
	<b>50 Hz</b>		<b>60 Hz</b>			
	50 034 01	346-460V	50 034 04	346-460V		
208	50 018 00	Skruv M4x12	Screw	Schraube	Vis	Y/D=2
209	50 018 04	Skruv M4x6	Screw	Schraube	Vis	Y/D=1
210	50 119 00	Flatsäftsbleck	Tab	Steckverbindung	Languette	Y/D=2
211	50 018 01	Skruv M4x8	Screw	Schraube	Vis	Y/D=3
212	50 078 00	Montageplåt	Mounting plate	Montageblech	Plaque pour montage	Y/D=1

Item No.	Part No.	Benämning	Denomination	Bezeichnung	Désignation	Quantity
213	50 035 03	Kabelhärva	Conductors, set	Leitungen, Satz	Conducteurs, compl.	DOL alt.1,2=1
214		Motorskydd	Motor protector	Motorschutzschalter	Disjoncteur	DOL alt.1,2,3=1
	<b>50 Hz</b>		<b>60 Hz</b>			
	50 034 00	190-240V	50 034 03	190-240V		
	50 034 01	346-460V	50 034 04	346-460V		
	50 034 02	500-575V	50 034 05	500-575V		
215	50 018 00	Skruv M4x12	Screw	Schraube	Vis	DOL alt.1,2,3=2
216	50 120 01	Flatstiftsbleck	Tab	Flachstecker	languette	DOL alt.1,2=3
217	50 018 00	Skruv M4x12	Screw	Schraube	Vis	DOL alt.1,2=2
218	DOL alt. 1	Kontaktor	Contacteur	Kontaktor	Contacteur	DOL alt.1=1
	<b>50Hz</b>		<b>60Hz</b>			
	50 353 19	500-550 V	50 353 19	575V		
218	DOL alt. 2	Kontaktor	Contacteur	Kontaktor	Contacteur	DOL alt. 2=1
	<b>50Hz</b>		<b>60Hz</b>			
	50 353 29	346V	50 353 29	380V		
	50 353 25	380-415V	50 353 30	460V		
219	50 018 04	Skruv M4x6	Screw	Schraube	Vis	DOL alt. 2,3=1
220	50 119 00	Flatstiftsbleck	Tab	Steckverbindung	Languette	DOL alt. 2,3=2
221	50 018 01	Skruv M4x8	Screw	Schraube	Vis	DOL alt. 2,3=3
222	50 356 00	Montageplåt	Mounting plate	Montageblech	Plaque pour montage	DOL alt. 2=1
223	DOL alt. 3	Kontaktor	Contacteur	Kontaktor	Contacteur	DOL alt.3=1
	<b>50Hz</b>		<b>60Hz</b>			
	50 353 39	200V	50 353 39	230V		
	50 353 69	220V				
224	133 743	Skruv M6x8	Screw	Schraube	Vis	DOL alt.3=3
225						
	50 330 01	Huvudkabelsats DOL	Supply cable set DOL	Hauptkabelsatz DOL	Jeu du câble principal DOL	DOL alt.3=1
	50 331 01	Manöverkabelsats	Pilot cable set	Pilotkabelsatz	Jeu du câble de commande DOL	alt.3=1
226	50 356 02	Montageplåt	Mounting plate	Montageblech	Plaque pour montage	DOL alt.3=1
300		Fasväxlare	Phase shifter	Phasenwechsler	Inverseur de phase	(1)
		0-16A	0-22A	0-22A	0-48A	
		Ø11-14,5mm	Ø10,5-16mm	Ø13-20mm	Ø13-20mm	
301		133 841	133 841	133 843	133 843	2
302		-	50 200 00	-	50 200 01	2
304		50 102 00	50 102 01	50 102 01	50 102 02	1
		Kopplingsschema	Wiring diagram	Schalt-schema	Schéma des connexions	
		50 & 60 Hz	50 & 60 Hz	50 & 60 Hz	50 & 60 Hz	1
	50 189 04	Y/D				
	50 189 06	DOL				DOL alt.1,2=1
	50 189 11	DOL 200-230V/ 50Hz				DOL alt.3=1
	50 189 12	DOL 230/460V 60Hz, 9-leads				DOL alt.2,3=1
		O-ringsats,	Set of O-rings,	O-Ringsatz,	Anneaux toriques,	
	50 085 02	bestående av:	comprising:	bestehend aus:	jeu comprenant:	
17	50 037 00	(1)	50 140 078	(1)		
20	131 656	(1)	103 130 623	(1)		
25	130 944	(1)	104 50 037 01	(1)		
48	140 075	(1)	106 140 323	(1)		
65	140 071	(1)	116 140 076	(1)		
66	140 077	(1)				
	5055310	Skruvskyddsats	Screw cap kit	Schrauben-kappe satz	Kit de chapeaux de vis	
		Olja	Oil	Öl	Huile	0.50L
		Vitolja	White oil	Weißöl	Huile cristalline	
		Viskositet ISO VG 15	Viscosity ISO VG 15	Viskosität ISO VG 15	Viscosité ISO VG 15	

Specifications can be changed without notice

**GRINDEX**

Grindex AB	Box 538	SE-136 25 Haninge	Sweden
Tel:+46 8 606 66 00		Fax:+46 8 745 16 06	
e-mail: grindex@grindex.com		www.grindex.com	



**MASKINSALG** <sup>A/S</sup>

UTSTYR FOR INDUSTRI OG ANLEGG

Blindheimsveien 1, 5131 Nyborg

[www.maskinsalg.com](http://www.maskinsalg.com)

SALG - SERVICE - UMLEIE Tlf. 55 19 96 20